

Prevention of Boiler Cold End Corrosion Using Water-fuel Emulsions

Dymo B.V., Kolbasenko O.V., Anastasenko S.M.
Admiral Makarov National University of Shipbuilding
Mykolaiv, Ukraine

Abstract. The objective of this study is to enhance the energy efficiency and environmental safety of boiler plants and engines equipped with waste heat recovery boilers. This objective is achieved by utilizing water-fuel emulsions as fuel for these boilers and engines. Using an experimental setup configured for the preparation and combustion of both standard fuels and water-fuel emulsions, the influence of the quality and composition of these emulsions on corrosion processes affecting heat exchange surfaces was investigated. The studies were conducted using emulsions with a water content ranging from 2% to 30%, fuels with a sulfur content of 0.98% to 2%, and an excess air ratio of 1.01 to 1.5, covering a tube wall temperature range of 70°C to 150°C. The most significant outcome of this study is the data demonstrating the absence of a corrosion peak and a substantial reduction in the corrosion penetration rate to acceptable levels (0.2...0.3 mm/year) when using emulsions with a 30% water content across a broad range of excess air ratios (1.01–1.15). Under these operating conditions, a passivation effect was also observed on the surfaces of the carbon steel boiler tubes. The significance of this research lies in the fact that the technology prevents or mitigates low-temperature corrosion on heat exchange surfaces, thereby enabling increased heat recovery from flue gases in boiler systems. For waste heat boilers in marine diesel engines, the heat recovery efficiency increases by 10–15%, as the exhaust gas temperature decreases from the design range of 160–180°C to values of 130–150°C.

Keywords: water-fuel emulsion, low-temperature corrosion, excess air.

DOI: <https://doi.org/10.52254/1857-0070.2026.2-70.15>

UDC: 612.181.27

Prevenirea coroziunii la capătul rece al cazanului folosind emulsiile apă-combustibil

Dîmo B.V., Kolbasenko O.V., Anastasenko S.M.

Universitatea Națională de Construcții Navale Amiralul Makarov, Mikolaiv, Ucraina

Rezumat. Obiectivul acestui studiu este de a îmbunătăți eficiența energetică și siguranța mediului înconjurător a centralelor termice și a motoarelor echipate cu cazane de recuperare a căldurii reziduale. Acest obiectiv este atins prin utilizarea emulsiilor apă-combustibil drept combustibil pentru aceste cazane și motoare. Folosind o configurație experimentală configurată pentru prepararea și arderea atât a combustibililor standard, cât și a emulsiilor apă-combustibil, a fost investigată influența calității și compoziției acestor emulsii asupra proceselor de coroziune care afectează suprafețele de schimb de căldură. Studiile au fost efectuate utilizând emulsii cu un conținut de apă cuprins între 2% și 30%, combustibili cu un conținut de sulf cuprins între 0.98% și 2% și un raport de exces de aer de 1,01 până la 1,5, acoperind un interval de temperatură al pereților tubului de la 70°C la 150°C. Cel mai semnificativ rezultat al acestui studiu îl reprezintă datele care demonstrează absența unui vârf de coroziune și o reducere substanțială a ratei de penetrare a coroziunii la niveluri acceptabile (0.2...0.3 mm/an) atunci când se utilizează emulsii cu un conținut de apă de 30% pe o gamă largă de rapoarte de exces de aer (1.01–1.15). În aceste condiții de funcționare, s-a observat și un efect de pasivizare pe suprafețele tuburilor din oțel carbon ale cazanelor. Semnificația acestei cercetări constă în faptul că tehnologia previne sau atenuează coroziunea la temperatură scăzută pe suprafețele de schimb de căldură, permițând astfel o recuperare crescută a căldurii din gazele de ardere din sistemele de cazane. Pentru cazanele de căldură reziduală din motoarele diesel marine, eficiența recuperării căldurii crește cu 10-15%, pe măsură ce temperatura gazelor de evacuare scade de la intervalul de proiectare de 160-180°C la valori de 130-150°C.

Cuvinte-cheie: emulsie apă-combustibil, coroziune la temperatură scăzută, exces de aer.

Предотвращение коррозии низкотемпературных поверхностей котлов с применением водотопливных эмульсий

Дымо Б.В., Колбасенко О.В., Анастасенко С.Н.

Национальный университет кораблестроения имени адмирала Макарова, Николаев, Украина

Аннотация. Целью работы является повышение энергетической эффективности и экологической безопасности котельных установок и двигателей, оборудованных утилизационными котлами. Поставленная цель достигается применением в качестве топлива котлов и двигателей водотопливных эмульсий. На экспериментальном стенде, оборудованном для приготовления и сжигания стандартных

топлив и водотопливных эмульсий, изучено влияние качества и состава водотопливных эмульсий на коррозионные процессы поверхностей теплообмена. Исследования выполнены при использовании эмульсий водосодержанием 2...30%, степени сернистости топлива 0.98...2%, и коэффициенте избытка воздуха 1.01...1.5 в широком диапазоне температур стенок труб от 70 до 150°C, включая и конденсационный режим процесса ниже температуры точки росы. Наиболее важным результатом работы являются полученные данные об отсутствии пика коррозии и существенном снижении скорости проникновения коррозии до допустимых значений 0.2...0.3 мм/год при водосодержании эмульсии 30% в широком диапазоне значений коэффициента избытка воздуха 1.01...1.15. На этих режимах также наблюдался эффект пассивации поверхностей котельных труб, выполненных из углеродистой стали, конденсатом серной кислоты при низких температурах стенок. Значимость выполненного исследования состоит в том, что технология применения водотопливных эмульсий, основанная на жесткой кавитационной обработке опресненной воды и стандартного судового топлива в гидродинамическом гомогенизаторе, предотвращает или снижает низкотемпературную коррозию на поверхностях нагрева и позволяет повысить глубину утилизации теплоты дымовых газов в котлах. Для утилизационных котлов современных судовых энергетических установок с малооборотными дизелями при сжигании водотопливных эмульсий коэффициент утилизации теплоты повышается на 10...15% при снижении температуры отходящих газов от расчетных 160...180°C до значений 130...150°C.

Ключевые слова: водотопливная эмульсия, низкотемпературная коррозия, избыток воздуха.

INTRODUCTION

The intensity pollution and corrosion of high-temperature and low-temperature heating surfaces during the combustion of sulfurous fuels greatly affect the reliability of power equipment and determine their mass-dimensional and economic indicators [1,2]. At surface temperatures t_w above 450°C, high-temperature corrosion (HTC) is observed, the rate of which depends on the fuel ash compounds (Na and V content, chlorine and other salts) and clearly enhances with increasing temperature t_w and the excess air coefficient α at which the fuel is burned. At boiler cold end surfaces with t_w below 140°C, due to condensation of sulfuric acid vapor, a sharp increase in the so-called low-temperature sulfuric acid corrosion (LTC) is observed. The intensity of corrosion under constant conditions already at t_w about 110°C reaches a maximum of 1.2 mm/year when burning standard sulfur fuels with $S^r = 2 \dots 3\%$ and $\alpha = 1.2$, which is called the peak of LTC, because after it at t_w below 100°C, the intensity of LTC sharply decreases.

Therefore, without applying special measures, there is no point in reducing t_w of the cold end surfaces of economizers and air heaters below 120...130°C, which significantly limits the efficiency of utilization, auxiliary and main boilers of the stationery and transport power plants. It is conceivable that one effective measure for preventing corrosion at boiler cold end surfaces could be the adoption of a specific water-fuel emulsion preparation technology, based on the preliminary purification and desalination of water in an electric dialyzer, followed by intensive cavitation treatment of

the mixture in a hydrodynamic homogenizer.

ANALYSIS OF RECENT RESEARCH AND PUBLICATION

In this regard, the data on the intensity of LTC, on the ranges of influence of changes in boiler operating parameters within and above the acceptable value of the corrosion rate (0.2...0.3 mm/year) at values in the range of 70...150°C and α at the level of 1.2...1.5 are relevant. Such parameters occur in real operating conditions of auxiliary boilers, which must be known when designing boilers and assessing the efficiency of operation, reliability and durability of power plant elements.

A large volume of data has been published and summarized in monographs [3-6], focusing on the formation of SO_3 and H_2SO_4 vapor, its condensation, and the intensity of LTC and fouling of cold end surfaces when burning standard fuel oils $W^r = 1.5 \dots 2,0\%$ at temperatures below the sulfuric acid dew point t_{ad} . Studies [5,7-10] provide a comprehensive overview of LTC mechanisms and various prevention methods, classifying approaches from fuel and air control to the use of chemical additives and temperature optimization.

In the combustion of water-fuel emulsions (WFE), a key factor influencing corrosion development is the determination of the dew point for both water vapor and sulfuric acid. This parameter has been studied in several works [11,12]. Research [11] indicates that the sulfuric acid dew point is calculated by accounting for both vapor-liquid equilibrium and multicomponent diffusion. Results show that fuel

type has a significant impact on the dew point; its value decreases with a reduction in the excess air ratio, an increase in wall temperature, and the condensation of acid vapors on ash particles. Furthermore, the geometry of the condensation surface (tubular or flat) plays a role. In the presence of fins, non-uniform dew point distribution across the heating surface may occur, which must be considered in heat transfer calculations [12]. It is also noted that predicting the H_2SO_4 dew point distribution interval, based on the Haase and Bergman models, is essential for preventing LTC in cold end boiler units.

Much attention in modern research is paid to the influence of the quality of alloys used for the manufacture of heat exchange surfaces on the intensity and dynamics of low-temperature corrosion [13]. In the work [9] the electrochemical nature of the corrosion development mechanism is indicated. The process proceeds in several stages with a stabilization stage. The presence of a stabilization stage is also indicated in [14]. Moreover, after the stage of increasing the corrosion intensity, a stage of its decrease is observed before remaining stable [15].

An important result of the study is the determination of the role of silicon oxide SiO_2 in the corrosion potential [16]. It was established that the increase in the Si content in steel is a key factor in improving its corrosion resistance, especially in the marine environment, affecting the composition and stability of the rust layer. In the work [14] on determining the stages of the process development, it was found that the minimum weight loss of pipes was recorded after 10 weeks of testing, while the maximum corrosion rate was observed in the second week. It was also found that the corrosion rate increased with increasing chloride ion concentration. Micro-structural analysis revealed the presence of a decarbonized film 240 μm thick on the flue gas side, as well as the formation of rust on the water side. Numerous pitting and crevice corrosion were also found there. To control such a process in [17] proposed the use of functionalized metal oxide nanoparticles due to their unique chemical and physical properties in aqueous media. The work also indicates the need for comprehensive planning of the development of corrosion on both sides of the heat exchange surface. An important conclusion of the work [18] is the confirmation of information about the special effect of hydrogen sulfide H_2S on the stability and corrosion resistance of stainless alloys due to the destruction

of the passive film, which usually protects stainless steel from corrosion.

Some studies [19,20] are focused on the consequences of low-temperature corrosion on the reliability and operational performance of thermal power facilities. In particular, in the work [19] the operational indicators of the Remming company's water heating boiler "Valjevo Heating Plant" with a capacity of 30 MW were studied due to the thinning of the walls of the pipes of the boiler unit's tail panel due to low-temperature corrosion. The work describes in detail the mechanism of the formation of sulfuric acid H_2SO_4 and the condensation of water vapor, which led to the thinning of the pipe walls. Attention is paid to the methods of restoring the heating surface of the bottom panel tubes and the role of the repair welding procedure when replacing this panel. Of particular interest for study are the data on the operation of the geothermal heat exchanger, which are presented in the work [20]. The processes that occur not in flue gases, but in the environment of sulfur vapors entering the heat exchanger from a geothermal well were studied. To study the corrosion processes, a digital model of the influence of acid deposition was developed. The results revealed a correlation between the distribution of acidic substances deposition in the heat exchanger and the condensation temperature of water vapor in accordance with its volume fraction. The similarity of the studied process of manifestation of the mechanism of low-temperature corrosion in flue gases is indicated.

One of the components of the technology of using water-fuel emulsions is the process of stabilizing the fuel mixture before feeding it into the combustion chamber. For this, surface-active substances (surfactants) are used [21,22]. As shown in [23,24], the use of stabilized emulsions affects the reduction of NO_x and soot particles emissions by 30...50%. It also has the effect of increasing combustion efficiency [25,26]. However, there are also significant disadvantages of adding surfactants to fuel emulsions, in particular, in the work [27] the possibility of increasing the level of corrosion of elements of fuel systems of engines and equipment of exhaust gas paths is indicated. Nevertheless, the use of surfactants to stabilize fuel emulsions has promise due to the development of so-called "smart surfactants" based on nanoparticles [17,28] and the development of emulsion quality monitoring systems, which may affect the reduction of

corrosion levels [29].

As is known, an alternative to the technology of burning WFE is the co-injection of hot water or superheated water vapor. The results presented in [30] show that when using superheated water vapor for fuel atomization, the temperature is reduced by 300...400 degrees and the emissions of nitrogen oxides NO_x are reduced by 30...50%. However, the concentration of CO and hydrocarbons C_nH_m increases. Combustion instability is also observed. However, the authors [30] believe that this technology has the potential for further study in connection with the development of innovative methods of liquid atomization. A comparison of different methods of fuel combustion in the presence of water (water-filled fuel, water-fuel emulsions and atomization with water and steam jets) are presented in the work [31]. It was investigated that the use of WFE improves the environmental performance of boilers without reducing their efficiency and service life. The use of water-filled fuels gives the lowest economic and environmental effect.

The analysis showed that the influence of fuel quality, its mineral composition, parameters and state of water-fuel emulsion and other factors on the intensity of low-temperature corrosion has not been sufficiently studied. Little data has been published on the intensity of low-temperature corrosion during the combustion of water-fuel emulsions [32-35] and there is no data on the influence of variable operating modes of the fuel oil burner on low-temperature corrosion. Moreover, only qualitative indicators of the processes are considered. The decrease in the speed of low-temperature corrosion is judged by the increase in the period between repairs of the fuel oil burner. The decrease in pollution is judged by the period between cleanings, which according to [32,33] increased by 2 times. The change in the mechanism of low-temperature corrosion is judged by the transition of local corrosion damage to uniform corrosion during combustion of WFE [32], which is obviously associated with the processes of passivation of the metal surface.

In accordance with [34,35] experimentally, and [8,13,36] theoretically were shown, when burning WFE with $W' = 30\%$, low-temperature corrosion processes at t_w within 70...130 °C occur in the passive state of the metal surface due to the absorption of N_2O_3 by the H_2SO_4 condensate. At the same time, the work [18]

indicates the possibility of point (local) destruction of the passive oxide film on the surface of metal pipes.

MATERIALS AND METHODS

The objective of this work is to conduct experimental studies and perform forecasting of the intensity of low-temperature sulfuric acid corrosion during the combustion of fuel oils and water-fuel emulsions within a cold end surfaces temperature range of 70...150°C.

Experimental studies were carried out on a multi-functional experimental setup, the schematic and description of which are provided in the authors previous works. The test stand was equipped with a dedicated working section for studying low-temperature and high-temperature corrosion processes. The section for investigating low-temperature corrosion was located in the low-temperature zone of the stand, where the flue gas temperature was below 250°C. The general view of this working section is shown in Fig. 1.

A bundle of sample tubes 2, made from the investigated steel grades, was placed on a mounting plate 1. Each tube was secured using a screw 3, nut 4, and spring 5 to ensure compensation for the thermal expansion of the samples. The sample tubes were fixed to the plate in a staggered arrangement with a pitch of 30 mm. The working section was equipped with instruments to measure the flue gas temperature before and after the tube bundle, a humidity and temperature sensor for measuring the dew point, flue gas flow and gas analyzer, as shown in Fig. 1 [37].

The general view of a sample tube used for corrosion research is shown in Fig. 2. The sample tube feature an internal cylindrical channel and are equipped with external fittings for the flow of cooling liquid. The temperature of the cooling liquid (water) was maintained at a controlled level using a flow-through thermostat.

Particular attention during the experimental research was paid to the preparation of the water-fuel emulsion.

The system schematic is shown in Fig. 3. Fuel and water are introduced into a mixing tank 1 in the required proportions depending on the target water content of the emulsion. A pump 2 ensures the circulation of the water-fuel mixture through a disperser 3 to obtain a stabilized emulsion with a water droplet size of 15...30µm. It is at this droplet size that the highest combustion quality of the WFE is achieved. If the pressure in the system exceeded the set limit before the disperser, a safety valve

4 would trigger, bypassing the emulsion back into the mixing tank 1. The full cycle of the WFE preparation technology based on two-

stage cavitation processing (soft and hard) was presented on Fig. 6 [38].

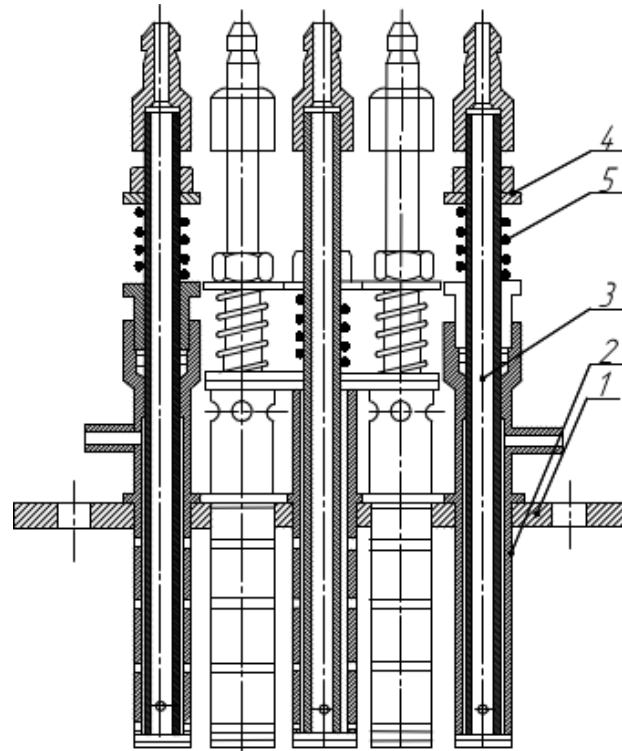

Fig. 1. Working section of the experimental setup for LTC research.

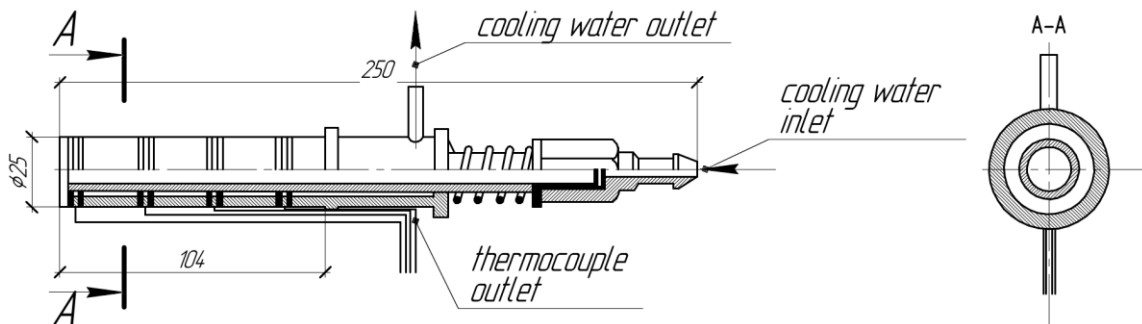

Fig. 2. General view of sample tubes with liquid coolant cooling.

The surface temperature of the sample tubes (Fig. 2) was measured using experimental thermocouples made of two thermoelectric electrodes (type $Cr/Ni - Cu/Ni$). The working junctions (sensors) were fixed in recesses on the tube surfaces, and the electrodes were routed along isothermal lines to minimize systematic measurement errors. Data registration was performed using a RegMik^R multi-channel digital thermometer. Data transfer from the secondary device to the control software on a personal computer was carried out via an RS-485 to USB

communication converter. The maximum permissible basic relative error for wall temperature measurements was $\pm 0.5\%$.

To measure the gas dew point in the range of $45...115^{\circ}C$, DVT-012 humidity and temperature sensors (accuracy class 2) were used (humidity error 2...3%, temperature error $0.3...0.5^{\circ}C$). Flue gas temperatures before and after the bundle were measured using laboratory thermometers (type TL-4) with an accuracy of $0.2...0.4^{\circ}C$, or standard thermoelectric thermometers type THK 102 RegMik^R with an accuracy of $0.4...1.0^{\circ}C$.

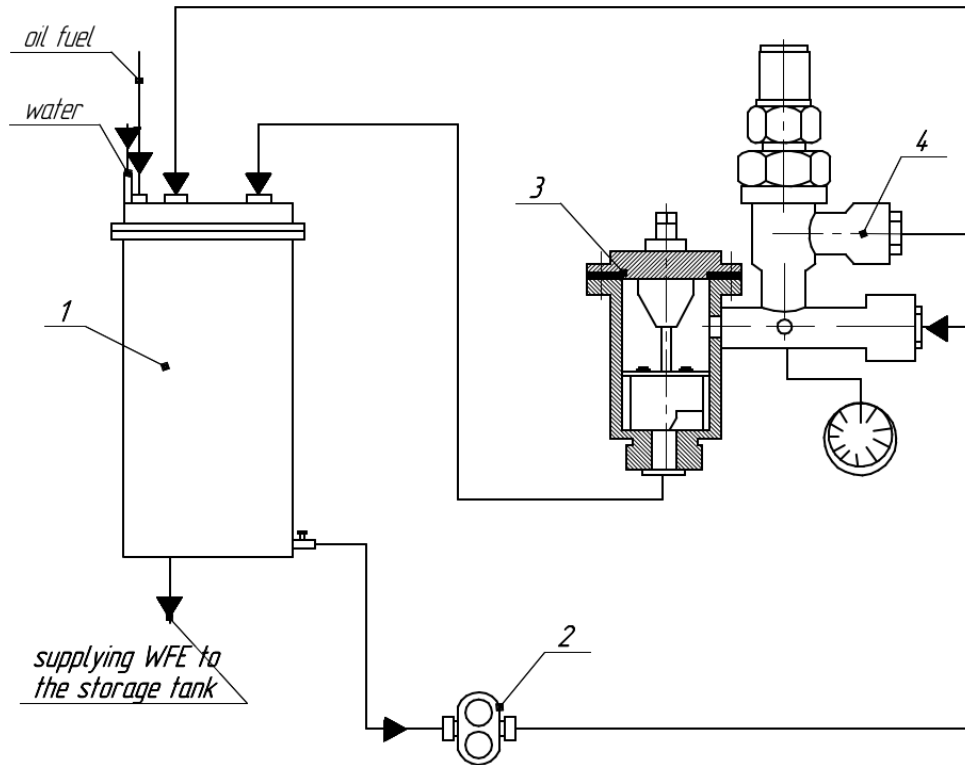

Fig. 3. Schematic of the water-fuel emulsion preparation unit.

The velocity, flow rate, and pressure of the flue gases were measured in the bypass duct using a piezometric probe (Fig. 1 [37]).

Analog signals from the primary differential pressure sensor were converted into digital code using differential and gauge integrated pressure sensor MPXV5004DP and an RS-485 converter. At flue gas velocities of 2...8 m/s, the relative measurement errors did not exceed:

- pressure and differential pressure: 0.5...1.5%;
- gas velocity: 1.0...1.5%;
- flue gas flow rate: 2.0...2.5%.

The kinetics of corrosion processes were studied using direct and indirect methods with capacitive-type sensors (error <2%). When using the direct gravimetric method, the specific metal loss ΔM , g/m², after exposure time (initial-final weight) was calculated as follows:

$$\Delta M = (m_1 - m_2) / F,$$

where m_1 - mass of sample tube before research, g; m_2 - mass of sample tube after cleaning of corrosion products and soot deposits, g; F - area of the outer surface of the sample tube, m².

The corrosion rate K , g/(m²·h) of the outer surface of the sample tube was determined as:

$$K = \Delta M / \tau,$$

where τ - is the duration of exposure to the corrosive environment, h.

To assess how quickly the wall material corrodes, significantly losing thickness over time, according to recommendation [2], the corrosion penetration rate was used. The corrosion penetration rate CPR , mm/year, was calculated as a statistical average value based on the corrosion rate using the following analytical relationship:

$$CPR = C \cdot \left(d - \sqrt{d^2 - \frac{35,04 \cdot K \cdot d \cdot h}{\rho}} \right),$$

where d – initial outlet diameter of sample tube, m; ρ – density of the material, kg/m³; K - corrosion rate, g/(m²·h); h – operating period, year; C – constant, the units used determine its magnitude ($C = 500$).

RESULTS AND DISCUSSION

25 series of experiments on the intensity of corrosion were performed at the experimental facility under conditions of variable parameters of water content W^r and sulfur content S^r in the fuel and excess air coefficient α . Control

extinction of metal loss from corrosion were carried out with study time marks of 2...100 hours. The reliability of the experiments was assessed by the values of the coefficient of determination R^2 at a level not lower than 0.92.

Fig. 4 shows the graphical dependences of the change in specific metal loss ΔM of the sample tubes after an 8-hour exposure at different values

of the parameters W^r , S^r and α . It was established that after a 2-hour exposure to the gas flow while maintaining constant process parameters, stabilization of corrosion processes was observed. In this case, the values of ΔM in the region of the acid corrosion peak were considered at wall temperature values in the range $t_w = 105...115^\circ\text{C}$.

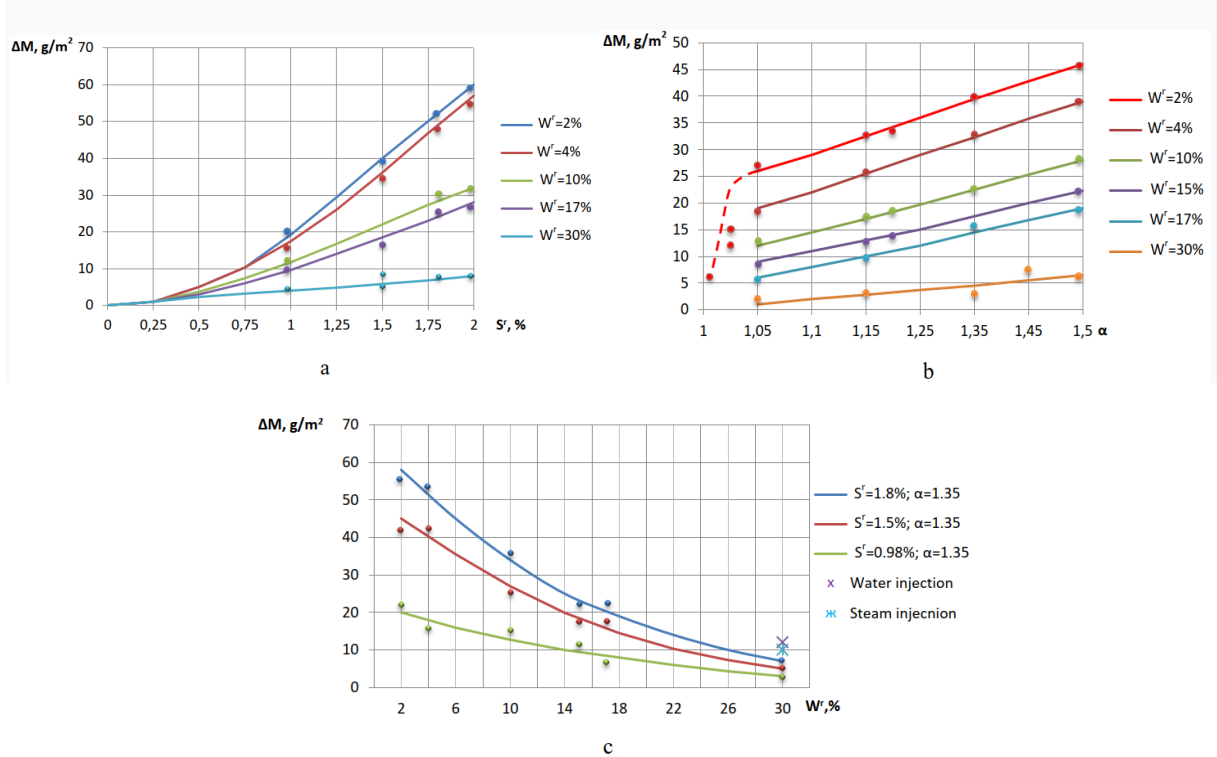

a - on the sulfur content S^r at different water content W^r of WFE; b - from excess air α at different water content W^r ; c - from the water content W^r at different sulfur content S^r .

Fig. 4. Dependence of the specific loss of ΔM metal due to LTC in the region of the acid peak at $\tau = 8h$:

With an increase in the sulfur content of more than 0.5% at any water content in the emulsion, an increase in ΔM is observed (Fig. 4, a), but its rate decreases with an increase in water in the emulsion. For example, when burning standard fuel with $W^r = 2\%$, with an increase in the sulfur content from 0.5 to 1.5%, ΔM increases from 5.5 to 40.0 g/m² (that is, the value of ΔM increased by 7.3 times), then a dt $W^r = 15\%$ ΔM increases to 30 g/m² at $S^r = 1.8\%$ (that is, the value of ΔM increased 6 times). When burning WFE with a content of $W^r = 30\%$, a slight increase in ΔM is observed: with an increase in the sulfur content S^r from 0.9 to 2.0%, ΔM increases from 3.5 to 9.0 g/m². That is, a loss of mass of metal is 5...8 times lower than when burning standard fuel. Moreover, it should be

noted that when water or water vapor is introduced into the furnace in an amount corresponding to 30% of water in the emulsion, the value of ΔM is lower than when burning standard fuel oil, but still higher than when burning WFE with the same water content.

Experimental data (Fig. 4,b) show that starting from $\alpha = 1.05$ and above, the dependence $\Delta M = f(\alpha)$ has an almost linear character. However, the feature of this relationship is not strictly proportional to the emulsion's water content parameter. For instance, as the air excess ratio increases from 1.05 to 1.45 during the combustion of an emulsion with $W^r = 2\%$, the specific metal loss ΔM varies from 26.5 to 43 g/m² i.e. an increase of 1.62 times. Conversely, at $W^r = 30\%$, ΔM increases from 2.5 to 6.0 g/m²,

representing a 2.4-fold increase. Experiments conducted at excess air ratios of 1.01 and 1.025 revealed a trend toward a sharp reduction in corrosion intensity when burning standard fuel. When using water-fuel emulsions in these modes, some process instability was observed due to the inability to maintain stable flame combustion. Therefore, the obtained data were not processed and require further verification.

As the water content in the emulsion increases, metal loss due to ΔM corrosion decreases, and the higher the sulfur content in the fuel, the steeper the curve of dependence $\Delta M = f(W^r)$ decreases (Fig. 4, c). Thus, with a sulfur content of 0.98%, ΔM decreases from 19.5 g/m² at $W^r = 2.0\%$ to 3.5 g/m² at $W^r = 30\%$ (i.e., ΔM decreased by 5.6 times). At a sulfur content of 1.8%, ΔM decreases from 58.0 g/m² at $W^r = 2.0\%$ to 7.5 g/m² at $W^r = 30\%$ (i.e., ΔM decreased by 7.7 times). The value of ΔM when water vapor and water are introduced into the

furnace in an amount corresponding to 30% of water in the WFE show that corrosion is more intense.

The fact that the curves of the intensity of the corrosion process at a water content in the emulsion of $W^r = 30\%$ with different sulfur content practically converge at one point can only be explained by the fact that at this water content in the emulsion, the conditions for the appearance of metal passivation are created. Experiments show that a solid salt layer is simultaneously created on the surface, which separates in the form of a thin film during the treatment of sample tubes after experiments with a solution of hydrochloric acid, and the surface of the metal has a characteristic shine during passivation. To assess the reliability of the research results obtained in 2...12 hours and the approximating dependencies for predicting corrosion intensity, control studies (5 modes) lasting up to 100 hours were conducted (Fig. 5):

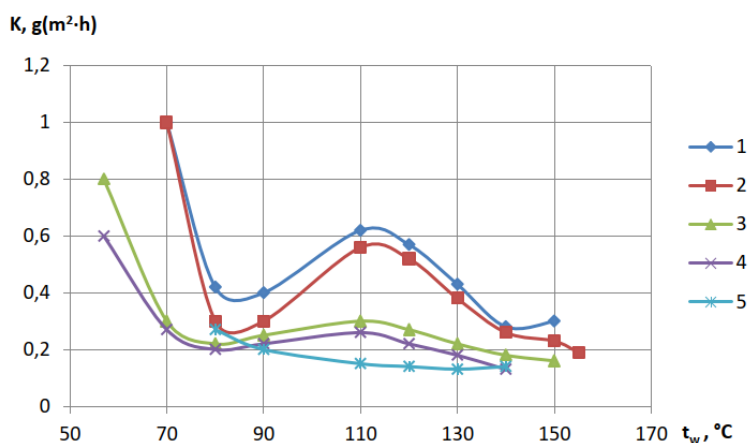

$\tau = 100h$; 2 - M100 ($S^r = 2.0\%$; $W^r = 2.0\%$), $\alpha = 1.025$, $\tau = 100h$; 3 - M100 ($S^r = 2.0\%$; $W^r = 2.0\%$) $\alpha = 1.01$, $\tau = 100h$; 4 - M 40 ($S^r = 0.98\%$; $W^r = 2.0\%$), $\alpha = 1.01$, $\tau = 100h$; 5 - WFE M40 ($S^r = 1.8\%$; $W^r = 30\%$), $\alpha = 1.45$, $\tau = 88h$.

Fig. 5. Dependence of $K = f(t_w)$ during combustion: 1 - M100 ($S^r = 2.0\%$; $W^r = 2.0\%$), $\alpha = 1.05$,

The results of 100-hour studies provide an opportunity to assess the accuracy of predicting the corrosion process for a long time based on studies of LTC kinetics with test durations of 2, 4, 8, and 12 hours, especially when burning water-fuel emulsions, for which there are no statistical data.

Obtained as a result of research on an experimental setup with constant parameters (constant α and t_w) the values of the speed of LTC for time $\tau = 100$ hours at $\alpha = 1.025$ and

1.05 practically coincide with the literature data [34,35] at the same values of α (corrosion rate $K = 0.7$ g/(m²·h) at $\alpha = 1.05$; $K = 0.6$ g/(m²·h) at $\alpha = 1.025$). At the value of $\alpha = 1.01$ the value $K = 0.24$ g/(m²·h). At these values, and when burning non-watered fuels for 100 hours, a small acidic peak is observed in the region of wall temperatures of 105...115°C. According to data [35], at $\alpha = 1.2$, the corrosion rate increases to 1.2 g/(m²·h).

When burning WFE ($W^r = 30\%$; $S^r = 1.8\%$) with an increased value of excess air and within 88 hours, the corrosion rate in this region of wall temperatures is almost 2 times

lower hotter compared to mode $\alpha = 1.01$ when burning non-watered fuel in the absence of a corrosion peak.

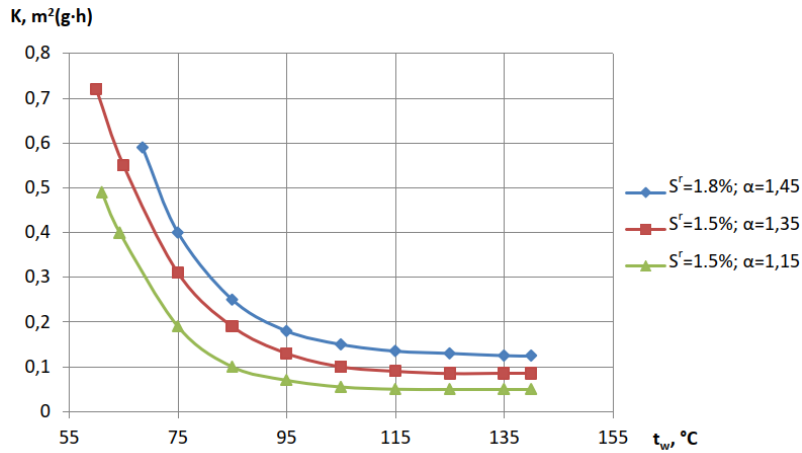

Fig. 6. Dependence corrosion rate on tw when burning WFE with $W^r = 30\%$ ($\tau = 100h$).

- $W^r=2\%; \alpha=1.05$ — $W^r=2\%; \alpha=1.025$ — $W^r=2\%; \alpha=1.01$
- $W^r=10\%; \alpha=1.35$ — $W^r=17\%; \alpha=1.2$ — $W^r=30\%; \alpha=1.45$
- $W^r=30\%; \alpha=1.35$ — $W^r=30\%; \alpha=1.15$

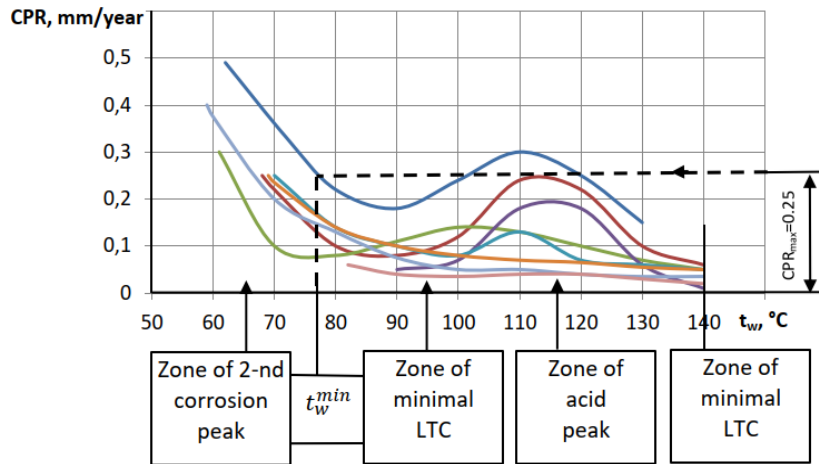

Fig. 7. Dependence of the corrosion penetration rate on the wall temperature for different modes of fuel combustion (prediction for $\tau = 1000h$).

In order to compare and evaluate the reliability of the data on the kinetics of corrosion processes obtained at the experimental installation, obtained within 2...12 hours, and then the values of the corrosion rate predicted for a long time period with the results of industrial studies, bench tests lasting 100 hours were conducted when burning M100 fuel oil with a sulfur content of 2%. After that, a recalculation was performed of the obtained data for 1000 hours using approximation formulas. This makes it possible to compare the results of bench and industrial studies and the

values of experimental data with the estimated predicted values obtained by the approximation formulas of the results of short-term experiments. In addition, it will give reason to consider reliable calculated values (for example, for 1000 hours) and for other modes of burning different fuels, for which there is no industrial data on the speed of corrosion processes over a long time. This especially applies to the burning regimes of interest to us, water-fuel emulsions. At the same time, it is necessary to take into account the influence of variable combustion parameters in

the furnace of the boiler, in contrast to the stability of these parameters in the furnace of the experimental installation [35].

It is especially necessary to note the results of LTC studies when burning WFE with (with sulfur content) at values of α in the range of 1.15...1.45 (Fig. 6), which show, that when the value of α is reduced to 1.15, the acceptable corrosion rate at the level of up to 0.3 g/(m²·h) (0.32 mm/year) occurs at values of the temperature of the heating surface up to 70°C. This means that in this case it is possible to supply feed water to the boiler economizer directly from the warm drawer (without intermediate heating). In addition, the absence of an acid peak makes it possible to ensure reliable operation of the economizer

surface (air heater) in this mode of WFE combustion when the boiler load changes. Considering the acceptable corrosion penetration rate of the metal of the economizer and air heater at the level of 0.25...0.35 mm/year, it can be argued that the most dangerous in terms of low-temperature corrosion is the wall temperature range 85...130°C, because this part the heating surface is subjected to intense influence of sulfuric acid condensate. At wall temperatures of about 130...150°C, the heating surface is still in the zone of electrochemical corrosion [40], but with ohmic control of the corrosion process due to the low acid content.

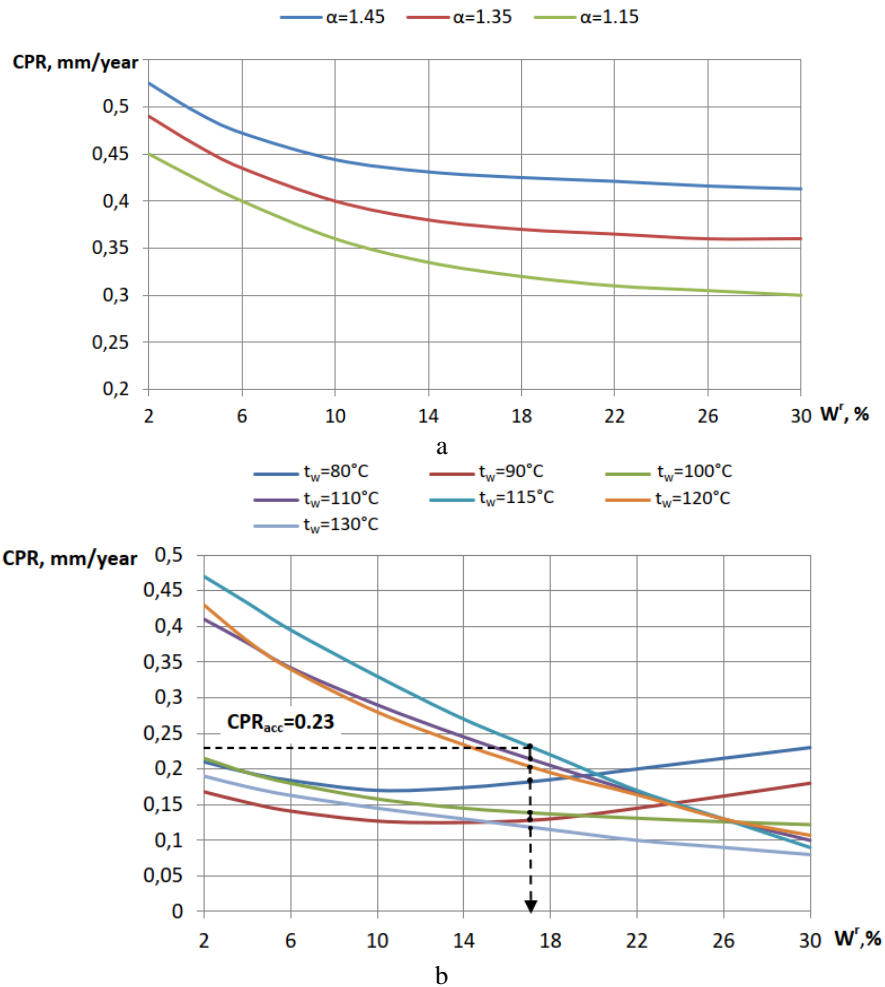

Fig. 8. Dependence of the corrosion penetration rate on the water content in the WFE in different temperature ranges of the boiler heating surfaces:

a – $t_w = 70^\circ\text{C}$, b – $t_w = 80...130^\circ\text{C}$.

At wall temperatures above 160...180°C, a mode of gas chemical corrosion is observed [41,42], and its rate corresponds or below to an acceptable value (the first minimum of corrosion). As the wall temperature decreases to

100...115°C, the corrosion when burning standard fuel oil increases sharply. In this range of wall temperatures, the first acidic peak of corrosion is observed and the corrosion is much higher than the acceptable level.

As the wall temperature further decreases, the corrosion decreases and the second corrosion minimum is reached [33,34]. In the temperature range of 80...90°C, there is a decrease in the intensity of corrosion to an acceptable level, mainly at low excess air. With high excess air, the corrosion rate is higher than the acceptable level. But because this range of wall temperatures is very narrow and is after the acid peak, it is difficult to use this phenomenon when designing low-temperature heating surfaces of the boiler. At wall temperatures below 75...80°C, with values of $\alpha > 1.05$, the corrosion rate increases sharply again (the second acid peak).

When burning WFE with different water content from 2 to 17%, a gradual decrease in the value of the corrosion peak is observed. If at $W^r = 4\%$ the maximum value of the corrosion penetration rate was 0.5 mm/year, then when burning WFE with $W^r = 10\% - CPR_{max} = 0.4$ mm/year, at $W^r = 17\% - CPR_{max} = 0,25$ mm/year. At the same time, the presence of a small corrosion peak is observed.

When burning WFE with a water content of 30% and an average value of $\alpha = 1.45$, it is already practical the first corrosion peak is not observed. Within the range of wall temperature from 140 to 70°C, the corrosion penetration rate is at the level of 0.15...0.3 mm/year. A decrease in the rate of is observed when the coefficient of excess air is reduced. When burning the same emulsion at $\alpha = 1.35$, the rate is 0.1 mm/year, at $\alpha = 1.15$ the rate is only from 0.05 to 0.1 mm/year within the range of wall temperatures from 140 to 80°C.

Therefore, with an increase in the water content in the WFE to 30%, the rate of corrosion processes of low-temperature heating surfaces in the area of the first acid peak decreases by 3...5 times.

The obtained data on the corrosion penetration rate at different wall temperatures during the combustion of WFE with different water contents from 2 to 30% make it possible to construct the dependences of the change in the corrosion rate on the water content at $\alpha = 1.35$ at characteristic wall temperatures in the zones (Fig. 7):

- dew point (130°C);
- acid corrosion peak (110, 115, 120°C);
- corrosion minimum (80...100°C);
- the second corrosion peak (70°C) at $\alpha = 1.35$ and $\alpha = 1.15$.

On the basis of experimental data as shown on Fig. 8,a, and subsequent predictions it were established that upon reaching $t_w = 70^\circ C$ with a water content of $W^r = 2...10\%$, the corrosion penetration rate initially sharply decreases from 0.45...0.55 mm/year to 0.365...0.44 mm/year. With a further increase in the water content to $W^r = 30\%$, the rate slowly decreases to the level of 0.3...0.415 mm/year. At the wall temperature at 80...90°C and W^r up to 10...12%, the corrosion penetration rate drops from 0.2 mm/year to 0.1 mm/year (Fig. 8,b). When the water content is further increased to $W^r = 30\%$, the rate begins to increase slightly. At temperatures of 100°C and 130°C with an increase in water content from $W^r = 2\%$ to 30%, the corrosion penetration rate gradually decreases from 0.195 mm/year to 0.115 mm/year and from 0.17 mm/year to 0.085 mm/year, respectively. But at t_w equal to 110, 115, 120°C (in the area of the acidic corrosion peak), with an increase in the water content in the emulsion to $W^r = 30\%$, the rate decreases significantly from 0.4...0.45 mm/ year to 0.1 mm/year.

Based on the data of these dependencies, it is possible to determine the limit of the corrosion penetration rate at different wall temperatures. The dependence curve $CPR = f(W^r)$ at $t_w = 115^\circ C$ characterizes the center of the zone of values of rates (with deviations of $\pm 10\%$), at which it is possible to pass over the acid corrosion peak (Fig. 8,b). That is, at this temperature corrosion is maximum, and at other temperatures, it is lower. The exception is the corrosion level at 70°C (Fig. 8,a). The value of these corrosion penetration rate is determined vertically from the point of intersection with the coordinates of the acceptable rate (CPR_{acc}) and W^r . In addition, it makes it possible to determine the amount of water content in the WFE, which ensures the acceptable value of the rate. For example, with the value of $CPR_{acc} = 0.23$ mm/year, the water content in the emulsion $W^r = 17\%$. With this water content in the WFE, the corrosion rate is lower at wall temperatures higher than 80°C and only at $t_w = 70^\circ C$ it exceeds the accepted value (Fig. 5,6). This makes it possible to accept exhaust gas temperature of 110°C (with a "gas-wall" temperature difference of 30°C). When the water

content in the emulsion is above 20%, there is a zone of minimum the corrosion penetration rate in the range of 0.2...0.25 mm/year in the entire range of wall temperatures from 80°C and above.

According to Fig. 8,a with an acceptable value of the corrosion penetration rate of 0.3 mm/year, the value of the wall temperature can be taken as 70°C only when $\alpha = 1.15$ and the water content in the emulsion is $W^r = 30\%$.

CONCLUSIONS.

Experimental studies of the intensity of low-temperature corrosion on boiler cold end surfaces were conducted. The influence of operating conditions and performance factors on the intensity and dynamics of the process was studied. The studies were performed using standard fuels and water-fuel emulsions. The process stages were determined, and dependences of the specific metal loss, corrosion rate, and corrosion penetration rate were obtained as a function of the emulsion water content, fuel sulfur content, and excess air ratio for different tube wall temperatures.

It was established that increasing the water content of the emulsion is an effective method for preventing and reducing the intensity of low-temperature corrosion. When burning water-fuel emulsions with a water content of 30%, the corrosion rate in the region of acidic peak decreases by a factor of 3...5.

It has been confirmed that, during combustion of water-fuel emulsions, reducing the excess air ratio to 1.05...1.07 also reduces the corrosion intensity for both standard fuels and water-fuel emulsions by limiting the formation of sulfur oxide. Further reductions in excess air to 1.0...1.025 are ineffective due to the development of unstable combustion conditions for water-fuel emulsions.

One of the key results of the study is the experimentally observed effect of boiler cold-end surface passivation during combustion of water-fuel emulsions at high water contents of 30%. The formation of a stable, dense protective layer inhibits the attack of sulfuric acid and effectively eliminates the acid peak of corrosion, which occurs at boiler cold-end surface wall temperatures of 110...115°C for standard fuels.

Operational threshold (acceptable) corrosion intensity values were determined. It has been established that when using a water-fuel emulsion with a water content of 30% and an excess air coefficient of 1.15, the corrosion rate

remains at an acceptable level of ≤ 0.3 mm/year at a boiler cold end surfaces temperature of $\geq 70^\circ\text{C}$.

The studies conducted demonstrate that the use of water-fuel emulsions is an effective method for improving the energy efficiency and environmental safety of modern boilers and engines equipped with waste heat boilers. A significant reduction in flue gas temperature by 20...30°C is possible by preventing corrosion while maintaining a boiler cold end surfaces temperature of 110...120°C, compared to the operating temperature of 140...160°C adopted when using standard fuels.

The obtained research results are of particular relevance for the marine power plants of modern ships equipped with low-speed long-stroke diesel engines such as MAN B&W ME-C or Win GD X. These engines are equipped with powerful turbochargers and gas cleaning systems (Selective Catalytic Reduction) and are characterized by low exhaust gas temperatures before the boiler of 220...260°C. At partial operating modes of the main engine, a special gas recirculation system (Economizer Energy Control) is used to maintain the boiler steam capacity. The condensing boiler cold end surfaces mode during combustion of water-fuel emulsion $W^r = 30\%$ in the MAN S60 ME-C8.5 engine with a capacity of 13,450 kW makes it possible to safely reduce the flue gas temperature behind the boiler to a level of 130...140°C instead of the operating mode 160...180°C and increase the heat utilization efficiency of the boiler by 10...15%.

REFERENCES

- [1] Roberge P.R. Handbook of Corrosion Engineering. 3rd ed. McGraw Hill, 2019. 800 p.
- [2] Mekonnen K.D. Corrosion fundamentals: Thermodynamics, rate, passivity, types, and control mechanism. Results in Surfaces and Interfaces, 2026, vol. 22:100720. [doi:10.1016/j.rsurfi.2026.100720](https://doi.org/10.1016/j.rsurfi.2026.100720)
- [3] Schweitzer P. A. Fundamentals of corrosion: mechanisms, causes, and preventative methods. CRC Press London, New York, 2010. 430p.
- [4] Gordon B. Fundamentals of Corrosion and Corrosion Control in LWRs. Structural Integrity Associates Inc., 2011. 147 p. Available at <https://www.nrc.gov/docs/ml1122/ML11229A047.pdf> (accessed 20.02.2026)

- [5] Kassem Y. Basics of Corrosion in Oil and Gas Industry: Corrosion science, forms, monitoring, and control. Amazon Digital Services LLC-Kdp, 2019. 213 p.
- [6] Luchkin, R.S. Korroziya i zashita metallicheskih materialov (strukturnye i khimicheskie faktory) [Corrosion and protection of metallic materials (structural and chemical factors)]. Electronic textbook. Tolyatti, TSU Publishing House, 2017. 269 p. (In Russian)
- [7] Kruger J., Begum S. Corrosion of metals: overview. Reference Module in Materials. Science and Materials Engineering, 2016, pp. 1-10. doi:[10.1016/b978-0-12-803581-8.02708-9](https://doi.org/10.1016/b978-0-12-803581-8.02708-9)
- [8] Parangusan H., Bradra J., Al-Thani N. A review of passivity breakdown on metal surfaces: influence of chloride- and sulfide-ion concentrations, temperature, and pH. Emergent Materials, 2021, vol. 4, pp. 1187-1203. doi:[10.1007/s42247-021-00194-6](https://doi.org/10.1007/s42247-021-00194-6)
- [9] Newman R.C., Williams D. Electrochemical fundamentals corrosion. [Encyclopedia of Electrochemical Power Sources. 2nd ed.](https://doi.org/10.1016/B978-0-323-96022-9.00244-9) 2025, vol. 1, pp. 167-171. doi:[10.1016/B978-0-323-96022-9.00244-9](https://doi.org/10.1016/B978-0-323-96022-9.00244-9)
- [10] Fontana M.G. Corrosion Engineering. 3rd ed. McGraw-Hill India, 2005. 575 p.
- [11] Bi C., Li D., Yang X., Lu Y., Zhang J. Prediction of Flue Gas Acid Dew Point Temperature Distribution Range in Boilers. IOP Conf. Series: Materials Science and Engineering, 2020, vol. 721, pp. 1-10. doi:[10.1088/1757-899X/721/1/012016](https://doi.org/10.1088/1757-899X/721/1/012016)
- [12] Wang Y.C., Tang G.H. Prediction of Sulfuric Acid Dew Point Temperature on Heat Transfer Fin Surface. Applied Thermal Engineering, 2016, vol. 98, pp. 492–501. doi:[10.1016/j.applthermaleng.2015.12.078](https://doi.org/10.1016/j.applthermaleng.2015.12.078)
- [13] Svintradze D.V., Ramana M., Pidararti A. A. Theoretical Model for Metal Corrosion Degradation. *International Journal of Corrosion*. Academic Editor: Omar S. Es-Said. Wiley Online Library, 2010. Available at doi:[10.1155/2010/279540](https://doi.org/10.1155/2010/279540)Digital (accessed 18.02.2026)
- [14] Sultan J.N., Abbas M.K., Ibrahim M.A.K., Karash E.T., Ali A.M., Ibrahim H.A. Corrosion Behavior of Thermal Seamless Carbon Steel Boiler. *Annales de Chimie Science des Matériaux*, 2021, vol. 45(5), pp. 399-405 doi:[10.18280/acsm.450506](https://doi.org/10.18280/acsm.450506)
- [15] Sun R., Yu Q., Zhang Y., Yan X., Lu Y., Zhang C., Wang Q. Effect of Si Content on the Corrosion Behavior of 420 MPa Weathering Steel. *Metals*, 2019, vol. 9(5):486. doi:[10.3390/met9050486](https://doi.org/10.3390/met9050486)
- [16] Wang, Z., Liu, J., Wu, L., Han, R., Sun, Y. Study of the corrosion behavior of weathering steels in atmospheric environments. *Corrosion Science*, 2013, vol. 67, pp.1–10. doi:[10.1016/j.corsci.2012.09.020](https://doi.org/10.1016/j.corsci.2012.09.020)
- [17] Tanaka H. Influence of Anions and Cations on the Formation of Iron Oxide Nanoparticles in Aqueous Media. *KONA Powder and Particle Journal*, 2022, vol. 39, pp. 119-129. doi:[10.14356/kona.2022003](https://doi.org/10.14356/kona.2022003)
- [18] Shah M., Ayob M.T.M., Rosdan R., Yaakob N., Embong Z., Othman N.K. The Effect of H₂S Pressure on the Formation of Multiple Corrosion Products on 316L Stainless Steel Surface. *The Scientific World Journal*, 2020, pp. 1-11. doi:[10.1155/2020/3989563](https://doi.org/10.1155/2020/3989563)
- [19] Milovanović N., Dorđević B., Tatić U., Sedmak S., Štrbački S. Low-temperature corrosion damage and repair of bottom panel tubes. *Structural Integrity and Life*, 2017, vol. 17, no. 2, pp. 125-131
- [20] Song C., Liu Z., Babaei M., Liu R., Hou G. Mitigating low-temperature corrosion in flue-gas heat exchangers for improving thermal storage efficiency in geothermal power plants. *Thermal Science and Engineering Progress*, vol. 52, 2024:10267. doi:[10.1016/j.tsep.2024.102673](https://doi.org/10.1016/j.tsep.2024.102673)
- [21] Vellaiyan S., Subbiah A., Kuppasamy S., Subramanian S., Devarajan Y. Water in waste-derived oil emulsion fuel with cetane improver: formulation, characterization and its optimization for efficient and cleaner production. *Fuel Processing. Technology*, 2022, vol. 228:107141. doi:[10.1016/j.fuproc.2021.107141](https://doi.org/10.1016/j.fuproc.2021.107141)
- [22] Gopidesi R.K., Rajaram P.S. A review on emulsified fuels and their application in diesel engine. *Int. J. Ambient Energy*, 2022, vol.43, pp. 732-740. doi:[10.1080/01430750.2019.1667410](https://doi.org/10.1080/01430750.2019.1667410)
- [23] Woo S., Lee K. Effect of injection strategy and water content on water emulsion fuel engine for low pollutant compression ignition engines. *Fuel*, 2023, vol. 343:127809. doi:[10.1016/j.fuel.2023.127809](https://doi.org/10.1016/j.fuel.2023.127809)
- [24] Gowrishankar S., Krishnasamy A. Injection system modification and optimization for performance enhancement and emission reduction in a light-duty diesel engine fuelled by biodiesel-water emulsion. *Fuel*, 2023, vol. 337:127222. doi:[10.1016/j.fuel.2022.127222](https://doi.org/10.1016/j.fuel.2022.127222)
- [25] Vellaiyan S. Enhancement in combustion, performance, and emission characteristics of a biodiesel-fueled diesel engine by using water emulsion and nanoadditive. *Renew. Energy*,

- 2020, vol. 145, pp. 2108-2120. doi:10.1016/j.renene.2019.07.140
- [26] Ayhan V, Ece. Y.M. New application to reduce NOx emissions of diesel engines: electronically controlled direct water injection at compression stroke. *Appl. Energy*, 2020, vol. 260:114328. doi:10.1016/j.apenergy.2019.114328
- [27] Vigneswaran R., Balasubramanian R.D., Sastha B.D.S.. Performance, emission and combustion characteristics of unmodified diesel engine with titanium dioxide (TiO₂) nanoparticle along with water-in-diesel emulsion fuel. *Fuel*, 2021, vol. 285:119115. doi:10.1016/j.fuel.2020.119115
- [28] Madusudanprasad M., Abshalomu Y., Dinesh R., Harish B.B., Bala S.S.R.M. Environmental Impact Mitigation in Diesel Engines Using Emulsified Water-in-Diesel Fuel Blended with Al₂O₃ Nanoparticles. *Problems of the Regional Energetics*, 2026, no. 1 (69), pp. 1-9. doi:10.52254/1857.0070.2026.1-69.01
- [29] Burke I., Salzer S., Stein S., Olusanya T.O.O., Thiel O.F., Kockmann N. AI-Based integrated smart process sensor for emulsion control in industrial application. *Processes*, 2024, vol. 12 (9):1821. doi:10.3390/pr120911821
- [30] Baidildina A.D., Nurgaliyeva A.T., Butakov E.B., Kopyev E.P., Sadkin I.S., Shadrin E.Yu. Study on the Co-atomization of Immiscible Liquids by a Superheated Steam Jet. *Case Studies in Thermal Engineering*, 2026, vol.77:107569. doi:10.1016/j.csite.2025.107569
- [31] Striha I. I., Seledtsov V. A., Martynov Yu. N. Ekologo-ekonomicheskaya effektivnost' szhiganiya vodomazutnykh emulsij v energeticheskikh kotlakh [Ecological economic efficiency of burning oil-water emulsions in power boilers]. *Izvestiya vysshikh uchebnykh zavedenij i energeticheskikh ob"edinenij SNG. Energetika – Reports from higher education institutions, and energy associations of the CIS. Energy*, 1996, no. 9-10, pp. 67-72 (In Russian)
- [32] Rezinskikh V.F., Grin E.A. Sovremennye problemy obespecheniya bezopasnosti teplomekhanicheskogo oborudovaniya pri prodlenii srokov ego sluzhby [Modern problems of ensuring safety of thermal and mechanical equipment during extension of its service life]. *Teploenergetika - Thermal Engineering*, 2013, no. 1, pp. 17-24. (In Russian).
- [33] Kornienko V.S. Issledovanie dinamiki nizkotemperaturnoi korrozii i zagryazneniya poverkhnostej nagreva utilizatsionnykh kotlov [Research of low temperature corrosion and pollution dynamics low-temperature heating surfaces of exhaust gas boilers]. *Ribne gospodarstvo Ukrainy - Fishing industry of Ukraine*, 2013, no. 3 (86), pp. 62-65. (In Russian)
- [34] Goryachkin V.Yu., Kornienko V.S. Intensivnost' korrozionnykh protsessov v utilizatsionnykh kotlakh pri szhiganii vodotoplivnykh emul'sij [Intensity of corrosion processes in exhaust gas boilers at burning water-fuel emulsion]. *Vestnik Astrakhanskogo gosudarstvennogo tekhnicheskogo universiteta. Seriya: Morskaya tekhnika i tekhnologiya - Vestnik of Astrakhan State Technical University. Series: Marine Engineering and Technology*, 2013, no. 2, pp. 101-110. (In Russian)
- [35] Gorbov V.M., Goryachkin A.V. Issledovanie intensivnosti korrozionnykh protsessov pri szhiganii vodomazutnykh emul'sij [Study of corrosion processes intensity during the combustion of water-fuel emulsions]. *Zbirnyk naukovykh prats' UDMTU - The collection of scientific works USMTU*, 2005, no. 5 (391), pp. 87-95. (In Russian)
- [36] Hibner E.L., Hack H., Scully J.R. Supplement to Corrosion Tests and Standards: Application and Interpretation. 2nd ed. ASTM International, 2022. 450 p.
- [37] Kolbasenko O.V., Dymo B.V., Anastasenko S.M., Shostak O.V. Features of Combustion of Water-fuel Emulsions with Different Methods of Introducing Water into the Combustion Zone. *Problems of the Regional Energetics*, 2025, no. 2 (66), pp. 178-189. doi:10.52254/1857-0070.2025.2-66.15
- [38] Filipshchuk A.N., Kolbasenko O.V., Shevtsov A.P., and Dymo B.V. Technology for Improving Technical, Economic and Ecological Efficiency of Boiler Plants Using Physico-Chemical Correction of the Water-Fuel Emulsions Composition. *Problems of the Regional Energetics*, 2021, no. 3 (51), pp. 62-77. doi:10.52254/1857.0070.2021.3-51.06
- [39] Magadeev V. Sh. Istochniki i sistemy teplosnabzheniya [Heat supply sources and systems]. Moscow, ID Energiya, 2013. 272 p. (In Russian)
- [40] Handbook of Industrial Water Treatment. Chapter 11. Preboiler & Industrial Boiler Corrosion Control. Available at <https://www.watertechnologies.com/handbook/chapter-11-preboiler-and-boiler-corrosion-control> (accessed 19.02.2026)
- [41] Kornienko V., Radchenko M., Radchenko R., Pavlenko A., Radchenko A. A new trend in combustion engine's deep waste heat recovery by application of condensing economizers in

exhaust boilers. *Applied Thermal Engineering*, 2024, vol. 261(1):125150.

[doi:10.1016/applthermaleng.2024.125150](https://doi.org/10.1016/applthermaleng.2024.125150)

- [42] Kornienko V., Radchenko R., Bondal L., Kukelka L., & Legutko S. Investigation of Condensing Heating Surfaces with Reduced

Corrosion of Boilers with Water-Fuel Emulsion Combustion. *Integrated Computer*

Technologies in Mechanical Engineering: Synergetic Engineering (ICTME 2020), Springer, 2021, pp. 300-309. [doi:10.1007/978-3-030-66717-7](https://doi.org/10.1007/978-3-030-66717-7)

Information about authors.



Dymo Borys Vasilovych, Candidate of Technical Sciences, Professor, Admiral Makarov National University of Shipbuilding, Mykolaiv.

Area of scientific interests: energy saving, heat exchange processes, two-phase thermosyphons.

E-mail:

dymobv@gmail.com



Kolbasenko Oleh Vasylovych, Doctor of Philosophy. Research

interests: energy saving, ecology, emulsion preparation, combustion processes in marine power plants.

E-mail:

rekamore45@ukr.net



Anastasenko Serhii Mykolaiovych, Candidate of Technical Sciences, Associate Professor, Admiral Makarov National University of Shipbuilding.

Research interests: energy saving, heat exchange processes, two-phase thermosyphons.

E-mail:

ondi2008@ukr.net