

Fractional Order PID Based Five-Step Li-Ion Battery Charger in Plug-in Hybrid Electric Vehicles

Manikandan M.¹, Mohamed Shuaib Y.²

¹Jyothishmathi Institute of Technology and Science, Karimnagar, Telangana, India

²B.S. Abdur Rahman Crescent Institute of Science & Technology, Vandalur, India

Abstract. The purpose of the research is to address the underutilization of electric machine-based propulsion in transportation despite its numerous advantages over conventional internal combustion engines (ICE), such as reduced emissions, lower fuel costs, and improved control and operation. To achieve this goal, the study reviews state-of-the-art energy sources, storage devices, power converters, and control strategies used in electric vehicles (EVs). It particularly focuses on the implementation of the five-level charging scheme for Lithium-ion (Li-ion) batteries, which are considered a promising solution for electric vehicle power storage. The important results of this work include the advantages of a five-level charging scheme for a 1Ah, 3.7V Li-ion battery compared with conventional charging methods, i.e., superior efficiency (97.16%), lower temperature rise (1.5 degrees Celsius), faster charging times (around 40-43 minutes), and extended battery lifespan. The significance of these results lies in their potential to address key drawbacks hindering the widespread adoption of plug-in hybrid electric vehicles (PH EVs) by offering a practical solution for faster, more efficient, and safer battery charging. By isolating the battery during charging and optimizing the charging process, the proposed system not only enhances the performance of electric vehicles but also contributes to prolonging the battery life, thus promoting sustainability in transportation. Additionally, the experimental validation using MATLAB Simulink underscores the practical feasibility of the proposed charging system, providing a valuable contribution to the field of electric vehicle technology.

Keywords: lithium-ion batteries, fractional order PID controllers, five-level charging plug-in, hybrid electric vehicles.

DOI: <https://doi.org/10.52254/1857-0070.2024.3-63.13>

UDC: 621.3

Încărcător de baterie Li-Ion în cinci trepte pe bază de PID controler fracționat pentru vehiculele electrice reîncărcabile hibride

Manikandan M.¹, Mohamed Şuaib Y.²

¹Gyothismathi Institutul of de Ştiinţă şi Tehnologie, Karimnagar, Telangana, India

²B.S. Institutul de Ştiinţă şi Tehnologie Abdur Rahman Crescent, Vandalur, India

Rezumat. Scopul cercetării este de a aborda subutilizarea propulsiei bazate pe maşini electrice în transport, în ciuda numeroaselor sale avantaje faţă de motoarele convenţionale cu ardere internă (ICE), cum ar fi emisiile reduse, costurile mai mici cu combustibilul şi controlul şi funcţionarea îmbunătăţite. Pentru a atinge acest obiectiv, studiul analizează sursele de energie de ultimă generaţie, dispozitivele de stocare, convertoarele de putere şi strategiile de control utilizate în vehiculele electrice (EV). Se concentrează în special pe implementarea unei scheme de încărcare pe cinci niveluri pentru bateriile cu litiu-ion (Li-ion), care sunt considerate o soluţie promiţătoare pentru stocarea energiei vehiculelor electrice. Rezultatele importante ale acestei lucrări includ simularea cu succes şi verificarea experimentală a schemei de încărcare pe cinci nivele pentru o baterie Li-ion de 1 Ah, 3.7 V. Analiza comparativă cu metodele convenţionale de încărcare demonstrează eficienţa superioară (97.16%), creştere mai mică a temperaturii (1.5 grade Celsius), timp de încărcare mai rapid (aproximativ 40-43 minute) şi durata de viaţă extinsă a bateriei. Semnificaţia acestor rezultate constă în potenţialul lor de a aborda dezavantajele cheie care împiedică adoptarea pe scară largă a vehiculelor electrice hibride plug-in (PHEV), oferind o soluţie practică pentru încărcarea bateriei mai rapidă, mai eficientă şi mai sigură. Prin izolarea bateriei în timpul încărcării şi optimizarea procesului de încărcare, sistemul propus nu numai că îmbunătăţeşte performanţa vehiculelor electrice, dar contribuie şi la prelungirea duratei de viaţă a bateriei, promovând astfel sustenabilitatea în transport. În plus, validarea experimentală folosind MATLAB Simulink subliniază fezabilitatea practică a sistemului de încărcare propus, oferind o contribuţie valoroasă în domeniul tehnologiei vehiculelor electrice.

Cuvinte-cheie: baterii litiu-ion, controlere PID de tip fracţionat, dispozitiv de încărcare cu cinci niveluri, vehicule electrice hibride.

Пятиступенчатое зарядное устройство на базе PID – регулятора дробного порядка для Li-ion гибридных перезаряжаемых электрических автомобилей
Маникандан М.¹, Мохамед Шуайб Ю.²

¹Институт технологий и науки Джйотишмати, Каримнагар, Телангана, Индия

²Б.С. Институт науки и технологий Абдура Рахмана Кресент, Вандалур, Индия

Аннотация. Целью исследования является решение проблемы недостаточного использования электрических машин на транспорте, несмотря на их многочисленные преимущества перед обычными двигателями внутреннего сгорания (ДВС), такие как снижение выбросов, снижение затрат на топливо, а также улучшение управления и эксплуатации. Для достижения этой цели в исследовании рассматриваются современные источники энергии, накопительные устройства, преобразователи энергии и стратегии управления, используемые в электромобилях (EV). Особое внимание уделяется реализации пятиуровневой схемы зарядки литий-ионных (Li-ion) аккумуляторов, которые считаются перспективным решением для хранения энергии электромобилей. Важными результатами этой работы являются преимущества пятиуровневой схемы зарядки литий-ионного аккумулятора емкостью 1 Ач, напряжением 3.7 В по сравнению с традиционными методами зарядки, а именно: превосходный КПД (97.16%), меньший рост температуры (1.5 градуса Цельсия), более быстрое время зарядки (около 40-43 минут) и увеличенный срок службы батареи. Значимость этих результатов заключается в их потенциале для устранения ключевых недостатков, препятствующих широкому внедрению гибридных электромобилей (PH EV), предлагая практическое решение для более быстрой, эффективной и безопасной зарядки аккумуляторов. Изолируя батарею во время зарядки и оптимизируя процесс зарядки, предлагаемая система не только повышает производительность электромобилей, но и способствует продлению срока службы батареи, тем самым способствуя экологичности транспорта. Кроме того, экспериментальная проверка с использованием MATLAB Simulink подчеркивает практическую осуществимость предлагаемой системы зарядки, внося ценный вклад в область технологий электромобилей.

Ключевые слова: литий-ионные аккумуляторы, ПИД-регуляторы дробного порядка, устройство пятиуровневой зарядки, гибридные электромобили.

INTRODUCTION

As the number of vehicles powered by conventional or ICE engines continue to rise, so does the need for crude oil. The removal of crude oil is using 4 billion tons each year [1-2]. There will be no more crude oil on the planet in a few years if consumption continues at its present rate. In addition, with 4.7 metric tons of CO₂ emissions per year on average, traditional automobiles are a major cause of climate change [3-4]. Electric cars, hybrid EVs, PHEVs, and other forms of electric vehicle hybrid technology are seeing increasing demand due to these important factors. The 25% reduction in CO₂ emissions compared to conventional cars is a major selling point for HEVs. In comparison to conventional vehicles, HEVs have an impressive 75% efficiency [5-6]. The US Environmental Protection Agency (EPA) estimates that in 2006, about 28% of total US GHG emissions came from the transportation sector (EPA, 2008). Interest has also grown in finding alternatives that help reduce the GHG emissions associated with the use of transportation fuels. Bio fuels, especially ethanol, are the alternative fuels that have gained the most attention and support: the US Energy Independence and Security Act (EISA) of (2007) requires fuel producers to use a minimum of 136 billion liters of biofuels in 2002 (EISA, 2007) [7]. Increased specific capacities and high-capacity

densities of negative electrode resulting from the employment of these hydride materials have been the reason for a considerable increase of energy storing capacity of cells manufactured there with NiMH batteries have continuously taken over the biggest part of the earlier NiCd market since that time [8]. However, sales of HEVs are not rising as quickly as expected due to a number of major drawbacks. A normal automobile will be less expensive than a hybrid electric vehicle (HEV). The high cost of HEVs is mostly attributable to the advanced technology that goes into their power generation. Half of a hybrid electric vehicle's total cost is attributable to its batteries [9-10]. Hybrid electric vehicles primary drawbacks are their slow speed, limited range, and long battery charging times [11]. Another major obstacle for PHEVs is the current state of the charging station infrastructure [12]. It could also improve the economics and technical performance of the electric utility industry and generate revenue to owners of plug-in hybrid electric vehicles (PHEV).

They lessen fuel usage because they employ the electric motor frequently (especially in slow traffic), because they shut down the IC engine when the vehicle has stopped for a predetermined amount of time, and because they recapture otherwise discarded kinetic energy during braking (Table 1) [13].

OBJECT, SUBJECT, AND METHODS FOR RESEARCH

The main objective of this work is to address the underutilization of electric machine-based propulsion in transportation despite its numerous advantages over conventional internal combustion engines (ICE), such as reduced emissions, lower fuel costs, and improved control and operation. To achieve this goal, the study reviews state-of-the-art energy sources, storage devices, power converters, and control strategies used in electric vehicles (EVs).

In the proposed work as shown in Figure 4, an efficient Battery Charger in Plug-in Hybrid Electric Vehicles is designed..The important results of this work include the successful simulation and experimental verification of the five-level charging scheme for a 1Ah, 3.7V Li-ion battery. Comparative analysis with conventional charging methods demonstrates superior efficiency (97.16%), lower temperature rise (1.5 degrees Celsius), faster charging times (around 40.43 minutes), and extended battery lifespan.

Table-1: Conventional and unconventional vehicle classifications.

Vehicle type	Engine	Advantages
Conventional	Internal combustion engine	Rapid starting, relatively quick acceleration and power regenerative braking and fuel savings
Hybrid electric vehicle (HEV)	Internal combustion engine with separate electric motor	
Plug-in hybrid electric vehicle (PHEV)	Larger electric motor and battery with smaller internal combustion engine	Can recharge at night to capture HEV benefits plus an all-electric range varying from 20 to 60 miles (about 30 to 100km) Captures PHEV benefits and can send power back to the grid
Vehicle-to-grid (V2G) PHEV	Larger electric motor and battery with smaller or eventually no internal combustion engine	

All the earlier mentioned charging schemes have drawbacks as high charging time. For the fast-charging battery it is required to increase the charging current when internal resistance of battery is low and decrease the charging current when internal resistance of battery is high it is required to decreased charging rate as shown in the Fig.1.

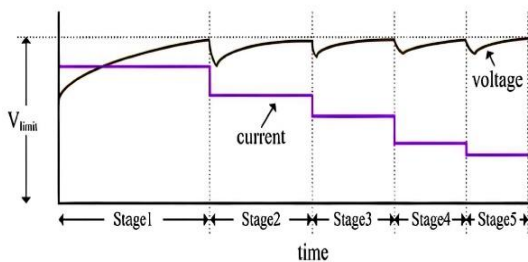

Fig.1. Five Step charging method. [14]

Because of this, the major challenge in auto-industry is to develop state-of-the-art battery system that complements the technology the most. There are two major areas: First is the reduction in parasitic losses in constant and variable-speed electric drive units through the diminution of belts, gears and multiple motor drives and the second area would be in electric mechanical drive including transmission, direct drive motors and remote controller “cable

connected” power electronics. Assuming that the vehicle is not assisted by an auxiliary energy source (AES), HEV usually can be divided into mild or medium hybrid electric vehicles (mild-HEV) and full-hybrid electric vehicles (Full-HEV).

$$HF = PEM / (PEM + PICE) \tag{1}$$

Currently, there are two ways to cascade the EM to ICE. One is by saving the same shaft with ICE and EM. The second one is by a power split path.

ANALYSIS OF THE MODEL AND THE METHODOLOGY OF ITS RESEARCH

A. ICEV & HEV

ICEV has a combustion chamber to transform chemical energy to heat energy and kinetic energy to propel a vehicle.

It has two types of vehicles: conventional ICEV which have no EM to assist and acquire lowest fuel economy and micro-hybrid electric vehicles (micro-HEV), which have EM with low operating voltage 14V (12V) and power not more than 5kW only to restart ICE from off state without contributing any power to propel the vehicle.

Nowadays, there are six types of drive trains architectures for HEV. Mild-HEV has an electric power of 7–12 kW with a 150V (140V) operating voltage and can run the car with ICE. It cannot, however, run without ICE (primary power) because they share the same shaft. Today, most of the carmakers have the same pace to produce full-HEV due to its use of split power path either running on just ICE or the EM, or both. The literature presents a variety of energy storage systems that are suitable for HEVs.

The electronic resistance encompasses the resistivity of the actual materials, such as the metal covers and internal components, as well as, how well these materials make contact with each other. The effect of this portion of the total effective resistance occurs very quickly and can

be seen within the first few milliseconds after a battery is placed under load [17].

With the distributed generation and energy storage systems being connected to the power grid, the power network structure becomes more complex.

The stressed power system becomes more difficult to control. The interest in battery electric vehicles (BEVs) and plug-in hybrid electric vehicles (PH EVs) has increased due to their impact on the redistribution of the pollution from tail pipes to smog stuck, low-cost charging, and reduced petroleum usage. Widespread adoption of BEVs/PHEVs will improve air quality and decrease the carbon footprint. [18].

TABLE-2. Comparison of Energy Storage Devices used in Electric Vehicles. [15]

Specifications	Super capacitors	Pb-Acid	Ni-Cd	Ni-MH	Li-ion	Fuel cells
Specific Energy (Wh/Kg)	4.2	41.75	56	77	163	3989
Specific Power (W/Kg)	1986	254	156	602	1003	82
Energy Density (Wh/l)	14.7	74.6	119.3	148	351	302
Power Density (W/l)	4879	93	56	476	598	503
Lifetime	105 cycles	500 cycles	2000 cycles	1500 cycles	1000 cycles	108x107 hours
Cost (Rs/kWh)	8,00,000	9,000	33,000	48,000	39,000	22
Commercialized Year	1992	1881	1960	1990	2010	2018
Charging time	Minutes	Hours	Hours	Hours	Ten of Minutes	<5 Minutes
Efficiency	1-1.2	1-1.1	0.9-1.1	1	0.9-0.98	0.8-1

TABLE-3. Comparison of various Lithium-ion Batteries. [19]

Specifications	LiCoO2	Li-Po	LiFePO4	LiNiCoAlO2	LiNiMnCoO2
Specific Energy (Wh/Kg)	158	198	116	150	150
Specific Power (W/Kg)	768	510	1016	765	1005
Energy Density (Wh/l)	556	503	403	608	402
Life time (cycles)	900	1900	1600	1200	1600
Cost (Rs/kWh)	32,000	96,000	32,000	33,000	31,000
Commercialized Year	1991	1994	1996	1999	2008

TABLE-4. Comparison of charging time for CCCV and Five level methods.

SoC (%)	CCCV method (sec)	Five level method (sec)
15	954	400
20	1849	690
40	3657	1215
50	5478	1660
60	6237	2090
70	7183	2516
80	8875	2990
90	10,079	3697
95	10,789	3910
100	-	4799

TABLE-5. Details of five level charging hardware results.

Level No.	Charging current (A)	SoC (%)	Charging time (sec)
1	1.5	0-20	0-392
2	1.2	20-46	392-890
3	0.9	46-79	890-2401
4	0.4	79-100	2401-4320

Research that analyzed several energy storage technologies displays the findings in Table I. When it comes to particular energy, fuel cells are head and shoulders above the competition output. With so many alternatives, choosing the right secondary battery for an electric car was a big hurdle when they first hit the market. One of the first innovations in the area of secondary batteries was lead acid, commonly spelled Pb-acid. When compared to other types of batteries, lead-acid batteries are more affordable. The low specific energy and energy density of this battery type make it unsuitable for usage in electric vehicles. Ni-Cd and Ni-MH cells were utilized in electric vehicle batteries in the past, but currently lithium-ion cells are the norm. The advantages of Li-ion batteries over other battery types are many and extensive, including superior specific energy, energy density, charging time, and many more. Despite being more expensive than alternatives, they meet all the criteria for an automotive energy source. A wide variety of minerals may serve as cathodes, such as lithium, cobalt oxide, phosphate iron, oxides of nickel and manganese and cobalt, and oxides of nickel and aluminum. The lithium-ion battery makes use of sulfur (Li-S) as one of its components. Table II [19]-[23]. In this project we had reduced the

distortion output with decreasing the time duration and the efficiency of the charging to the Li ion battery had managed to be stable.

A Li-ion battery is unique, as it is charged from a fixed voltage source that is current limited (this is usually referred to as constant voltage charging).

B. Constant Voltage Charging Method (CVCM)

A Constant voltage (C-V) charger sources current into the battery in an attempt to force the battery voltage up to a pre-set value (usually referred to as the set-point voltage or set voltage). Once this voltage is reached, the charger will source only enough current to hold the voltage of the battery at this constant voltage (hence, the reason it is called constant voltage charging). At present, the major Li-ion cell manufacturer recommends 4.200 +/- 50mV as the ideal set point voltage, and 1c (a charging current rate equal to the A-hr rating of the cell) as the maximum charging current that can be used. A typical charge profile for a Li-ion cell using 1c constant voltage charging is shown in Fig.2.

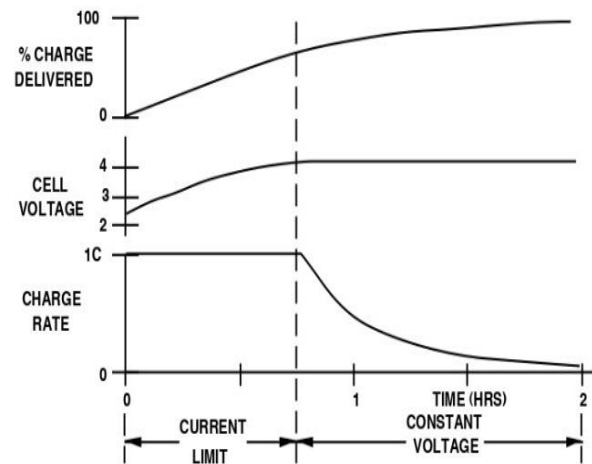

Fig.2. C-V Charge run time. [24]

Energy storage systems (ESSs) are of critical importance in electric, hybrid electric and plug-in hybrid electric vehicles (EVs, HEVs, and PHEVs). Although batteries with higher power densities are available, they are typically priced much higher than their lower power density counterparts. In addition, thermal management is a challenge for batteries to safely work in high power-load conditions not only to cool down the battery, but also to warm up the battery in cold temperatures in order to reach the desired power limits. This condition is especially severe when the battery is used to do high-rate charge and discharge.

METHODS FOR RESEARCH

A. Protection of the Battery from Over current

UC HESS is to fully utilize the significantly higher power limits of the UC to support acceleration and fully recover energy

Table-6. Typical characteristic of battery cells.

Chemistry	Nominal Cell Voltage (Volt)	Energy Density (Wh/Kg)	Power Density (kW/kg)	Cycle life (Times)
Lead Acid	2	30-40	0.18	Up to 800
Ni-Mh	1.2	55-80	0.4-1.2	Up to 1,000
Li-ion	3.6	80-170	0.8-2	Up to 1,200
Li-Polymer	3.7	130-200	1-2.8	Up to 1,000
Li-Iron Phosphate	3.2/3.3	80-115	1.3-3.5	Up to 2,000

The discharging power limit ensures that no additional power is drawn from the battery during aggressive acceleration while the charging power limits force the hybrid controller to activate mechanical brake early in order to absorb the portion of extra energy that cannot be taken by the battery.

through regenerative braking. These frequent charges are typically current surges caused by unpredictable regenerative braking. If this surge is injected directly into a battery without regulating, the battery could die very quickly.

Conventional HESS connects the UC via a dc/dc converter to satisfy the real-time peak demands of the power train controller.

The proposed HESS achieves this in a different way, which can be considered an application of the averaging concept. The UDDS is a driving cycle standard that is designed to simulate city driving in the U.S.

The procedure involves charging the battery at five distinct current levels, as shown in Fig. 1. Upon reaching the maximum voltage of the battery, each level will end. When trying to charge Li-ion batteries quickly, employing high charging currents has a few downsides, such as joule heating and lithium plating. Consequently, when the resistance is low, increase the charging current; when the resistance is high, lower it. This will cause the battery to charge quicker.

The internal resistance of the battery plotted against the system on a chip is shown in Fig. 2. The battery's internal resistance is low when the state of charge (SoC) is low (as shown in Fig. 2) and high when the SoC is high. When the system on-chip (SoC) level is low, the suggested charging currents for the battery are low, and vice versa when the SoC level is high (Fig. 3). The most significant challenge with this approach, however, is determining the best charging current levels at each stage.

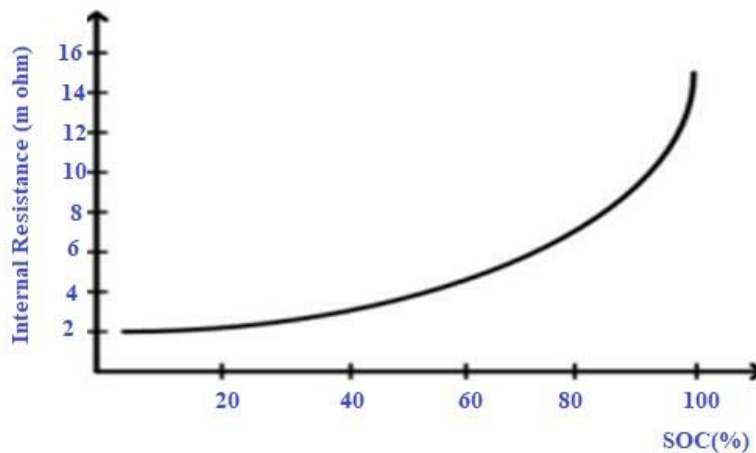

Fig.3. Battery internal resistance.

B.HESS Method

At each step, the ideal currents were 1.5C, 1.25C, 0.9C, 0.65C, and 0.4C, according to optimization studies conducted on this and current and limited battery charging patterns [14]. As nice as it might

be, adding many charging levels would need the same expensive hardware circuitry. This research proposes a closed-loop current-regulated DC-DC converter-based five-stage battery charging procedure. You can see the circuit in Fig.4.

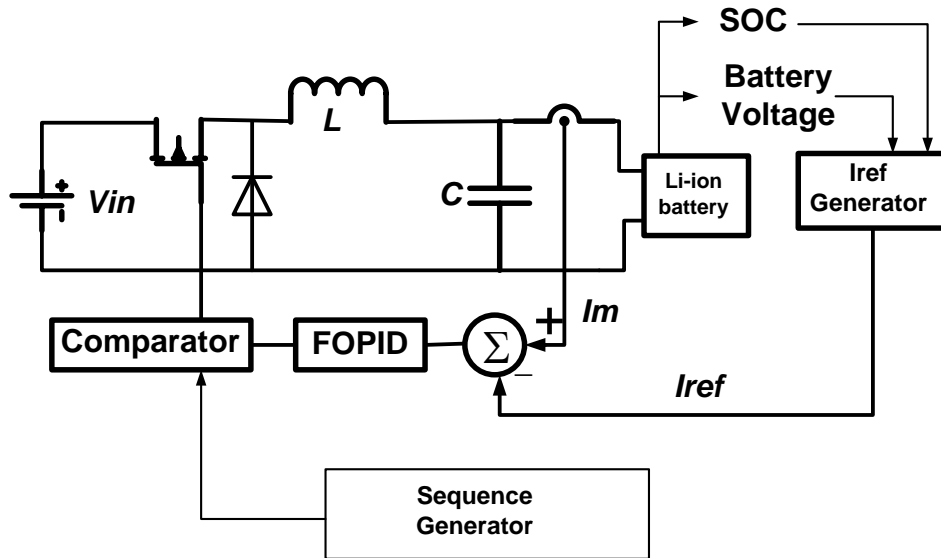

Fig.4. Implementing five-level charging schemes with a FOPID controller via a charging circuit.

The above fig.4 is a MATLAB/SIMULINK circuit diagram showing the five-level charging methods utilizing the FOPID controller. The battery charges completely in thirty minutes to thirty-five minutes. By precisely controlling the charging current until full charge, the total charging time of the battery is reduced. Nearing the conclusion of the charging cycle, a current

of 0.4C is seen. The efficiency and longevity of the battery are enhanced by this multistage current charging method. The battery will not be damaged if the charging is interrupted at 0.4C. In contrast to the conventional controller, the proposed controller produces smooth current.

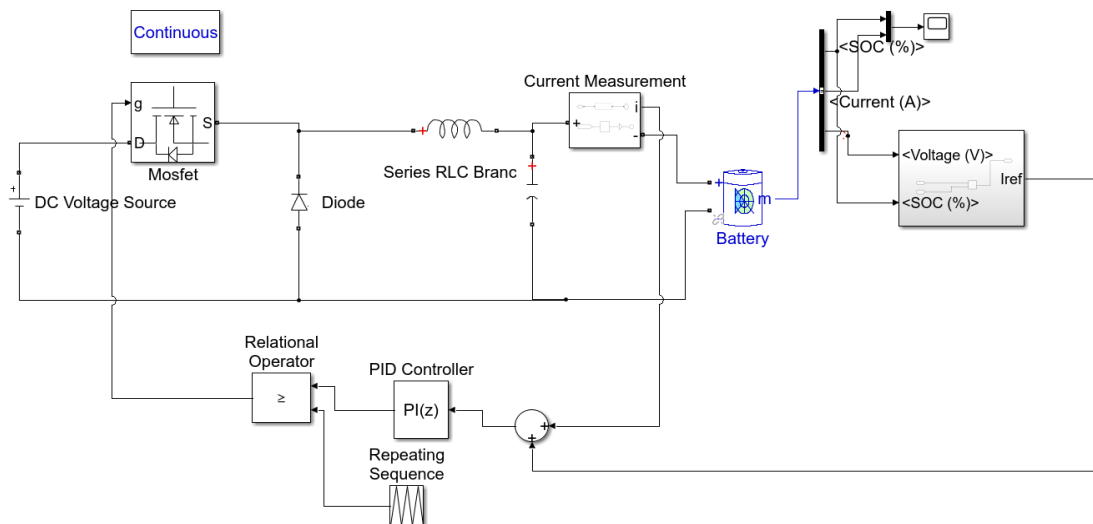

Fig.5. MATLAB/SIMULINK circuit diagram of five level charging scheme with PI controller.

The above fig.5 is a MATLAB/SIMULINK circuit diagram showing the five-level charging methods

utilizing the PID controller. The battery charges completely in thirty minutes to thirty-five minutes.

By precisely controlling the charging current until full charge, the total charging time of the battery is reduced.

Nearing the conclusion of the charging cycle, a current of 0.4C is seen.

RESULTS AND DISCUSSION

The efficiency and longevity of the battery are enhanced by this multistage current charging method. The battery will not be damaged if the charging is interrupted at 0.4C. In contrast to the conventional controller, the proposed controller produces smooth current.

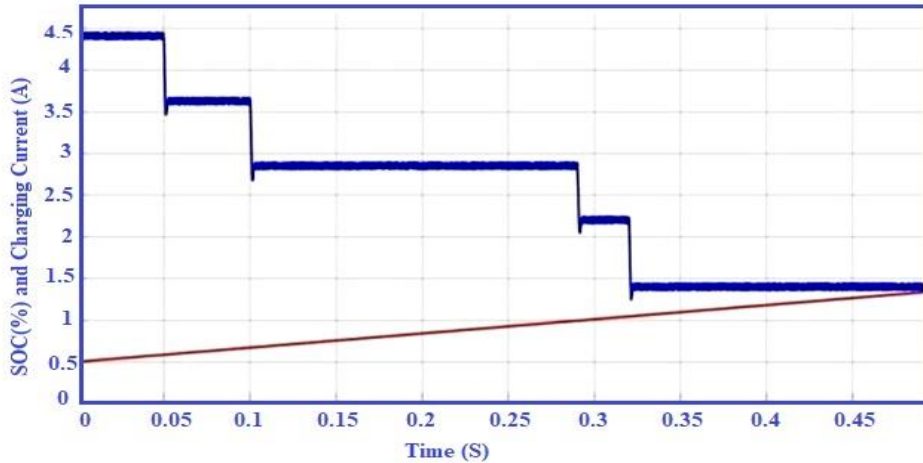

Fig.6: Five level charging results with PI controller.

In Fig. 6, the five-level charging method may completely charge a battery in around 1.5 to 1 hour. Reducing the total charging time of the battery is achieved by accurately managing the charging current until full charge. The charging

cycle is almost complete when a current of 0.4C is seen. This multistage current charging process improves the battery's efficiency and lifespan. Interrupting the charging process at 0.4 °C will not harm the battery.

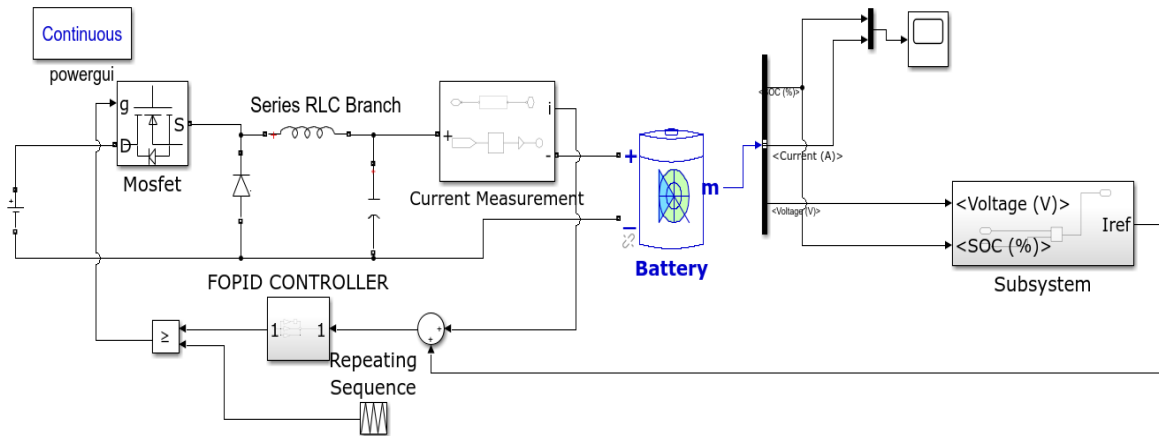

Fig.7. Schematic of five-level charging systems using FOPID controller in MATLAB/SIMULINK.

In the Fig. 7, there is a MATLAB/SIMULINK circuit diagram showing the five-level charging methods utilizing the FOPID controller. The battery charges completely in 30 to 35 minutes. By precisely controlling the charging current until full charge, the total charging time of the battery is reduced. Nearing the conclusion of the charging

cycle, a current of 0.4C is seen. The efficiency and longevity of the battery are enhanced by this multistage current charging method. The battery will not be damaged if the charging is interrupted at 0.4C. In contrast to the conventional controller, the proposed controller produces smooth current.

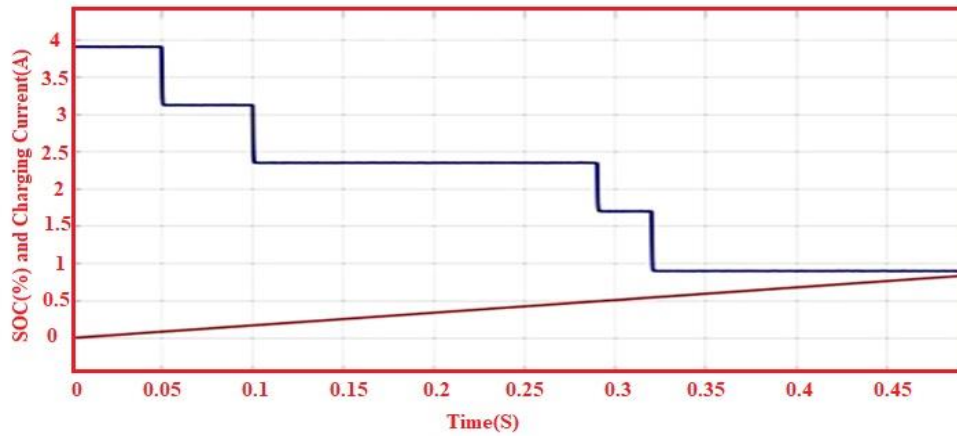
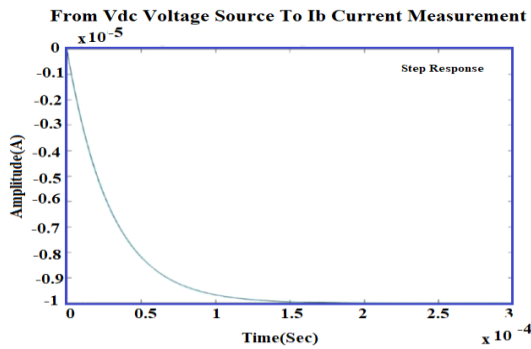

Fig.8. Five level charging results with FOPID controller.

The fig 8 is a MATLAB/SIMULINK; the five-level charging method may completely charge a battery in around 1.5 to 1 hour. Reducing the total charging time of the battery is achieved by accurately managing the charging current till

full charge. The charging cycle is almost complete when a current of 0.4C is seen. This multistage current charging process improves the battery's efficiency and lifespan. Interrupting the charging process at 0.4C will not harm the battery.



(a)

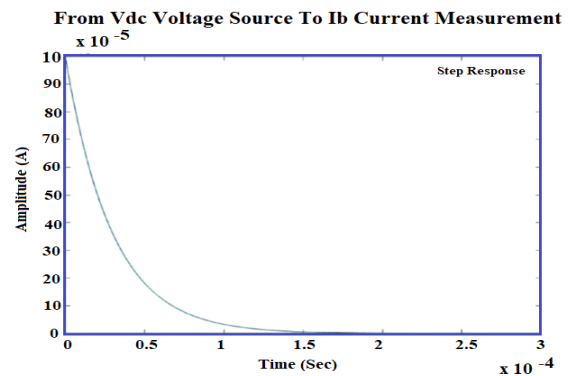

(b)

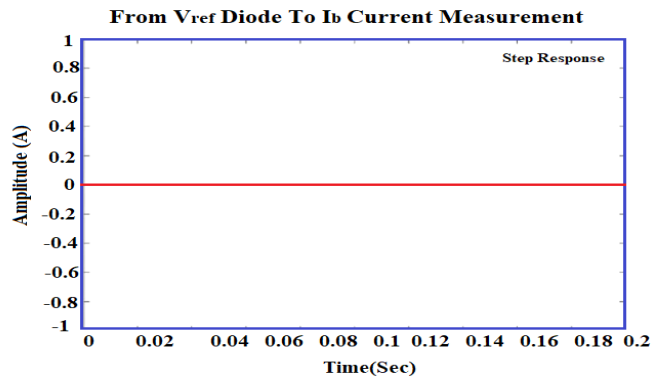

(c)

Fig.9. Step response of the Battery (a) voltage source as input battery current measurement as output, (b) Battery voltage source as input battery current measurement as output, (c) Input as Diode throughout the battery current measurement.

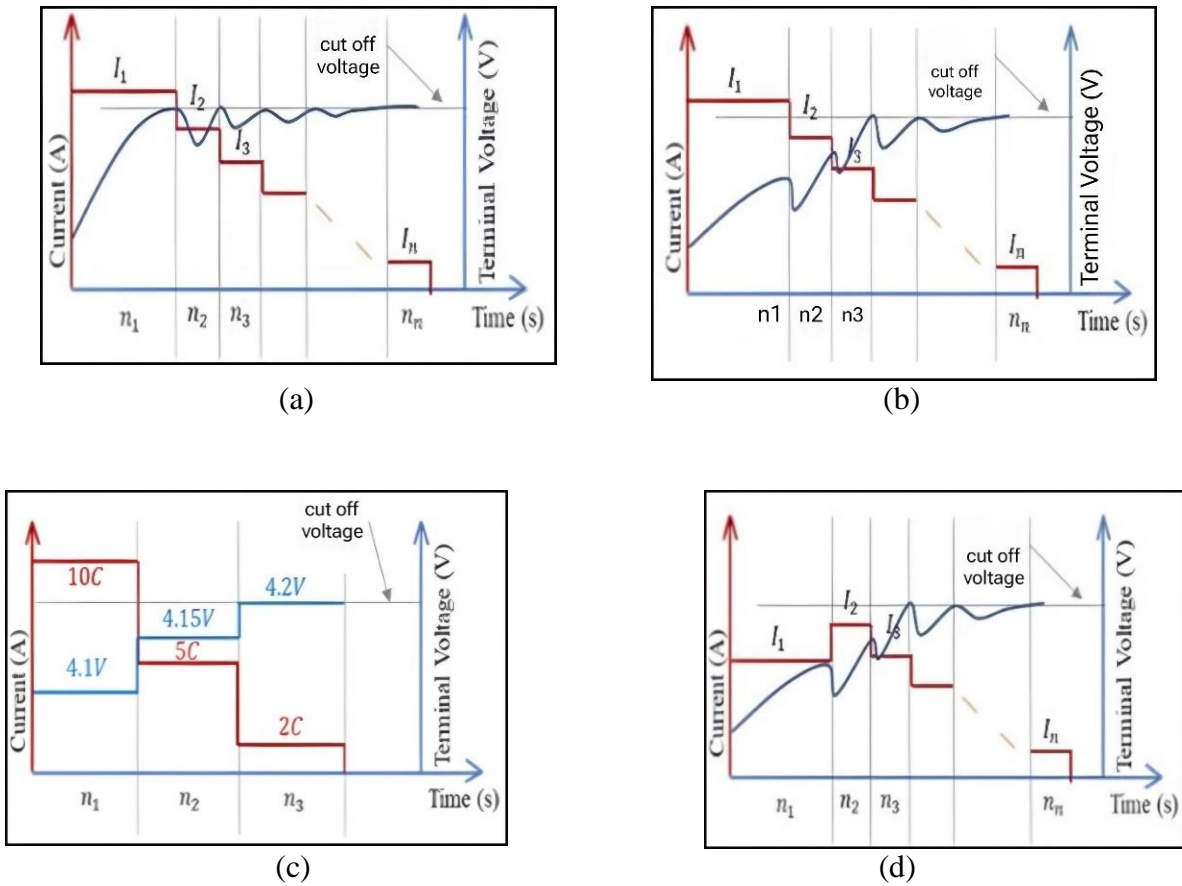

Fig. 10. Schematic diagram of the five-Stage Charging Current (MSCC) Protocol where (a) The charging current stage changes whenever the battery voltage reaches the cut-off voltage, (b) the Hierarchical technique (HT), (c) the Conditional random technique (CRT), and (d) five level multistage constant current-constant voltage superfaster charging (ML MCC-CV) methodology.

In the Fig.9 the step response of the battery is taken. And here the common supply is to the battery current measurement. When the time increases the amplitude of the voltage source and battery controlled voltage source is getting decreased gradually. The diode makes a form of supply to the battery current measurement as linearly.

In the Fig.10 the cutoff voltage compares the battery voltage to the predetermined cutoff voltage. When the battery voltage reaches this threshold, the comparator triggers a change in the charging current stage. This change is executed through charge current control circuitry, which may include switches or a variable current source controlled by the charging controller. Here the cutoff voltage compares when the terminal voltage is getting increased gradually then the current gets decreased in the same medium for the respective time. When the conditional random technique is used the terminal voltage at the threshold points the current and the

voltage gets across each other but for the cutoff voltage gets gradually changed. For the five-level multistage constant current-constant voltage superfaster charging (ML MCC-CV) methodology we can observe that as per the voltage increases in the period of time intervals the current gets reduced.

In the Fig.11 the various types of the standard positive pulsed charging current (PPCC) protocols as of the standard protocol with equal duty cycle consists of the constant change in the time for a periodic distance with respect to the current.

The standard protocol with various duty cycles has irregular lengths and the waveforms are not similar. In the distance between the respective adjacent sides of the waves we can see the changes.

For the standard protocol with the decaying current we can observe with respect to the time the current is gradually decreasing. In the standard protocol with upper and lower current limit the

current is taken as the in between the I_{High} and I_{Low} . However, in the different pulse charging voltages, the voltages are changed in magnitude, and the time is being measured in a periodic manner. This research consists of an automatic control system where the circuit is analyzed and

stabilized. The simulation output is obtained with less distortion, and the time duration of the supply did not change. When the charging is taking place, the constant supply is applied, and the accuracy of the output is taken out. When the simulation is processed, the output is obtained with high efficiency and a stable supply.

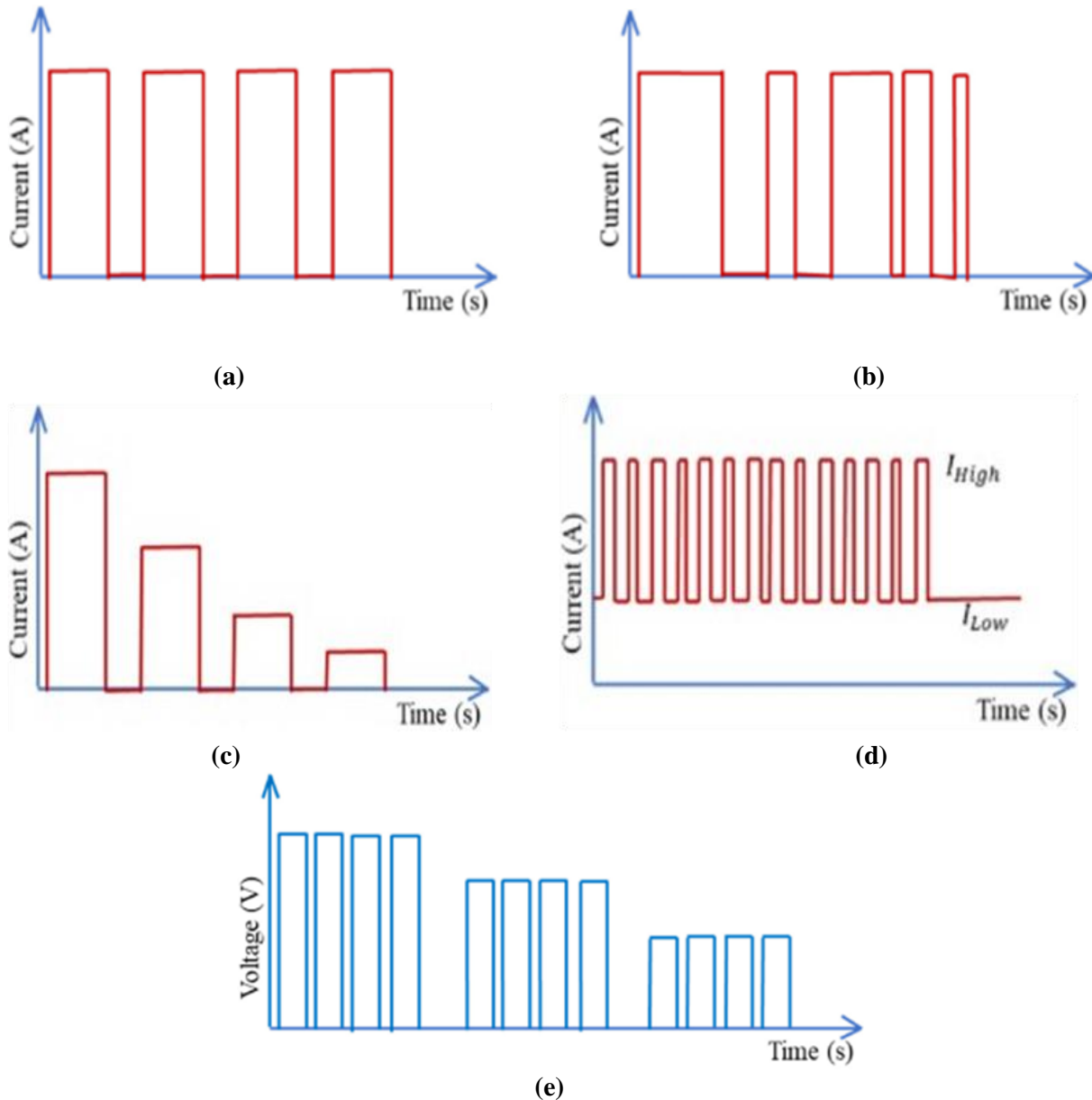

Fig.11. Types of the Standard Positive Pulsed Charging Current (PPCC) Protocol; (a) standard protocol with equal duty cycle, (b) standard protocol with various duty cycle, (c) standard protocol with decaying current, (d) standard protocol with upper and lower current limit, and (e) different pulse-charge voltages.

CONCLUSION

The research shows the current up-to-date status and implementation of the lithium-ion battery for fast charging protocols, it has been divided into two processes. First, one is power management protocols and second is thermal management protocols, current voltage and temperature are the parameters for the research. The efficiency is increased by 62.78% from the traditional method. The charging infrastructure and battery technology were to improve by using the proposed method. In this study, we ran the suggested charger circuit through PSIM, a modelling program, to make sure it is right. The simulation results of the five-step charging strategies developed by PI and FOPID are contrasted. The simulation results demonstrate that the five-step method is sixteen times faster than the traditional method. At the outcome of the work, a proposed charger can charge the electric vehicle batteries with higher efficiency 97.16%. Lower temperature rise 1.5-degree Celsius, fast charging around 40.43 minute and long-life cycle. This work was tested by MATLAB Simulink.

REFERENCES

- [1] Kutasovic and Paul R, "Changes in Supply of and Demand for Crude Oil Price," NMIMS Management Review, pp.7-20, April 2012.
- [2]Owen, Nick A and Inderwildi, Oliver R and King, David A, "The status of conventional world oil reserves-Hype or cause for concern?" Energy Policy, vol. 38, pp. 4743-4749, Aug 2010.
- [3]"Greenhouse Gas Emissions from a Typical Passenger Vehicle," United States Environmental Protection Agency, May 2014.
- [4] Jaramillo, Paulina and Samaras, Constantine, "Comparing life cycle GHG emissions from coal-to-liquids and plug-in hybrids,"CEIC Working Paper, June 2007.
- [5]Tie, Siang Fui and Tan, Chee Wei, "A review of energy sources and energy management systems in electric vehicles,"Renewable and Sustainable Energy Reviews, vol. 20, pp. 82-102, April 2013.
- [6]Sovacool, Benjamin K and Hirsh, Richard F, "Beyond batteries: An examination of the benefits and barriers to plug-in hybrid electric vehicles (PHEVs) and a vehicle-to-grid (V2G) transition."Energy Policy, vol. 37, pp. 1095- 1103, Mar 2013.
- [7]Yilmaz, Murat and Krein, Philip T, "Review of battery charging topologies, charging power levels, and infrastructure for plug-in electric and hybrid vehicles," IEEE Transactions on Power Electronics, vol. 28, pp.2151-2169, May 2013.
- [8] Sovacool, Benjamin K and Hirsh, Richard F, "Beyond batteries: An examination of the benefits and barriers to plug-in hybrid electric vehicles (PHEVs) and a vehicle-to-grid (V2G) transition."Energy Policy, vol. 37, pp. 1095- 1103, Mar 2013.
- [9] Yilmaz, Murat and Krein, Philip T, "Review of battery charging topologies, charging power levels, and infrastructure for plug-in electric and hybrid vehicles," IEEE Transactions on Power Electronics, vol. 28, pp.2151-2169, May 2013.
- [10] Tie, Siang Fui and Tan, Chee Wei, "A review of energy sources and energy management system in electricvehicles," Renewable and Sustainable Energy Reviews, vol. 20, pp. 82-102, April 2013.
- [11] I.EnergizerHoldindgs, "Battery Internal Resistance.
- [12] Pang, Chengzong, Papiya Dutta, and MladenKezunovic, "BEVs/PHEVS as dispersed energy storage for V2B uses in the smart grid," IEEE Transactions on Smart Grid, vol. 3, pp.473-482, Mar 2012.
- [13] Egbue, Ona and Long, Suzanna "Barriers to widespread adoption of electric vehicles: An analysis of consumer attitudes and perceptions,"Energy Policy, vol. 48, pp.717-729, Sep 2012.
- [14] Denholm, Paul and Short, Walter, "Evaluation of utility system impacts and benefits of optimally dispatched plug-in hybrid electric vehicles (revised)," National Renewable Energy Laboratory, Golden, CO.,Oct 2006.
- [15] Chan, Ching Chuen and Chau, KT, "An overview of power electronics in electric vehicles," IEEE Transactions on Industrial Electronics, vol. 44, pp.3-13, Feb 1997.
- [16] Liu, Yi-Hwa and Luo, Yi-Feng, "Search for an optimal rapid-charging pattern for Li-ion batteries using the Taguchi approach," IEEE Transactions on Industrial Electronics, vol. 57, pp.3963-3971, Dec 2010.
- [17] Goutam, Shovon and Timmermans, Jean-Marc and Omar, Noshin and Bossche, Peter Van den and Van Mierlo, Joeri, "Comparative study of surface temperature of commercial Li-ion pouch cells of different chemistries and capacities by infrared thermography,"Energies, vol. 8, pp.8175-8192, Aug 2015..
- [18] Omar, N and Van den Bossche, P and Mulder, G and Daowd, M and Timmermans, JM and Van Mierlo, J and Pauwels, S, "Assessment

of lithium iron phosphate oxide, nickel manganese cobalt oxide and nickel cobalt aluminum oxide based cells for using in plug-in battery electric vehicle applications,” IEEE Vehicle Power and Propulsion Conference, pp.1-7, Jul 2011.

[19] Babu V., Ahmed K.S., Shuaib Y.M., Mani M. (2021) A novel intrinsic space vector transformation based solar fed dynamic voltage restorer for power quality improvement in distribution system. Journal of Ambient

Intelligence and Humanized Computing. doi:<https://doi.org/10.1007/s12652-020-02831-0>

[20] T. Praveen Kumar S. Ganapathy, M. Manikandan, (2022) Improvement of voltage stability for grid connected solar photovoltaic systems using static synchronous compensator with recurrent neural network, Electrical Engineering & Electromechanics, Issue, 2 page 69-77. doi: <https://doi.org/10.20998/2074-272X.2022.2.10>

Information about authors.



Dr. Manikandan M, Ph.D., Professor, Department of Electrical and Electronics Engineering. Jyothishmathi Institute of Technology and Science, Telangana, India. Field of scientific interest is Power Quality in Electrical Distribution systems, electric vehicles.
E-mail: cm.manikandan@gmail.com



Dr. Mohamed Shuaib Y., Ph.D., Professor, Department of Electrical and Electronics Engineering. 2B.S. Abdur Rahman Crescent Institute of Science & Technology, Vandalur, India. Field of scientific interest is Power Quality in electrical distribution systems, electric vehicles.
E-mail: mdshuaiby@crestent.education